

Owner's Manual & Safety Instructions

Save This Manual Keep this manual for the safety warnings and precautions, assembly, operating, inspection, maintenance and cleaning procedures. Write the product's serial number in the back of the manual (or month and year of purchase if product has no number). Keep this manual and the receipt in a safe and dry place for future reference.

24j

PREDATOR®

13,000 WATT TRI-FUEL GENERATOR

10,000 GAS RUNNING WATTS
13,000 MAX GAS STARTING WATTS

9100 LPG RUNNING WATTS
12,000 MAX LPG STARTING WATTS

7800 NG RUNNING WATTS
10,000 MAX NG STARTING WATTS

Visit our website at:
<https://www.harborfreight.com>

Email our technical support at:
productsupport@harborfreight.com

Email our engine support at:
predator@harborfreight.com

71386

WARNING: Improper installation, adjustment, alteration, service, or maintenance can cause injury or property damage. Refer to this manual. For assistance or additional information consult a qualified service technician, service agency, manufacturer, or the gas supplier.

FOR YOUR SAFETY IF YOU SMELL GAS:

1. Don't touch electrical switches.
2. Extinguish any open flame.
3. Immediately call your gas supplier.

FOR YOUR SAFETY

Do not store gasoline or other flammable vapors and liquids in the vicinity of this or any other generator.

⚠ DANGER

Using a generator indoors CAN KILL YOU IN MINUTES.

Generator exhaust contains carbon monoxide. This is a poison you cannot see or smell.

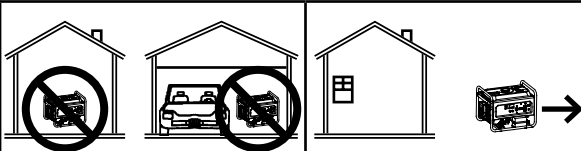

NEVER use inside a home or garage, **EVEN IF** doors and windows are open.

Only use **OUTSIDE** and far away from windows, doors, and vents.

⚠ DANGER

Do not use in trailers, truck beds, or tents.

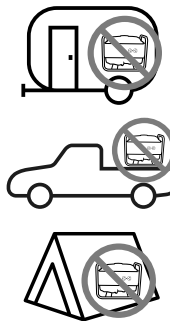

Use at least 20 feet away from people, animals, and structures with exhaust pointed away. Generator will produce carbon monoxide when burning gas, LPG, or NG.

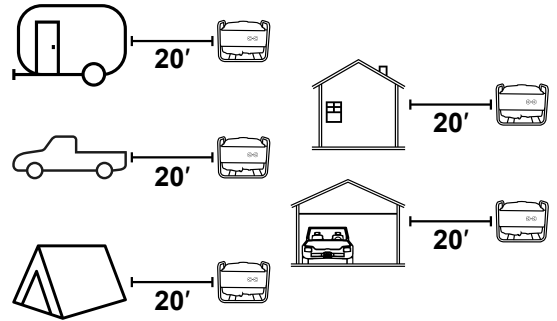

When unpacking, make sure that the product is intact and undamaged. If any parts are missing or broken, please call 1-800-444-3353 as soon as possible.

Copyright© 2024 by Harbor Freight Tools®. All rights reserved.

No portion of this manual or any artwork contained herein may be reproduced in any shape or form without the express written consent of Harbor Freight Tools. Diagrams within this manual may not be drawn proportionally. Due to continuing improvements, actual product may differ slightly from the product described herein.

Tools required for assembly and service may not be included.

⚠ WARNING

Read this material before using this product. Failure to do so can result in serious injury. SAVE THIS MANUAL.



IF YOU SMELL GAS

- 1. NO FLAMES OR SPARKS!**
Immediately put out all smoking materials and other open flames. Do not operate lights, appliances, telephones, or cell phones. Flames or sparks from these sources can trigger an explosion or a fire.
- 2. LEAVE THE AREA IMMEDIATELY!**
Get everyone out of the area where you suspect gas is leaking.
- 3. SHUT OFF THE GAS.** Turn off the main gas supply valve on your propane tank or the shutoff valve on the natural gas source if it is safe to do so. To close the valve, turn it to the right (clockwise).
- 4. REPORT THE LEAK.** From a neighbor's home or other nearby building away from the gas leak, call your propane retailer or local gas company right away. If you can't reach your propane retailer or gas company, call 911 or your local fire department.
- 5. DO NOT RETURN TO THE AREA** until your propane retailer, the gas company, emergency responder, or qualified service technician determines that it is safe to do so.
- 6. GET YOUR SYSTEM CHECKED.** Before you attempt to use your generator your propane retailer, the gas company, or a qualified service technician must check your entire system to ensure that it is leak-free.

CAN YOU SMELL IT?

Propane smells like rotten eggs, a skunk's spray, or a dead animal. Some people may have difficulty smelling propane due to their age (older people may have a less sensitive sense of smell); a medical condition; or the effects of medication, alcohol, tobacco, or drugs.

ODOR LOSS. On rare occasions, propane can lose its odor. Several things can cause this including:

- The presence of air, water, or rust in a propane tank or cylinder
- The passage of leaking propane through the soil

Natural Gas itself is odorless and tasteless, but a chemical is added to give it an odor in order to help detect leaks quickly. Natural Gas is lighter than air and will collect in higher areas.



Since there is a possibility of odor loss or problems with your sense of smell, you should respond immediately to even a faint odor of propane or natural gas.

GAS DETECTORS

Under some circumstances, you may not smell a propane or natural gas leak. Propane and natural gas detectors (not included) sound an alarm if they sense propane or natural gas in the air. They can provide an additional measure of security. You should consider the purchase of one or more detectors for your home.

GUIDELINES regarding propane or natural gas detectors:

- Buy only units that are listed under the latest Underwriters Laboratories (UL) standard.
- Follow the manufacturer's instructions regarding installation and maintenance.
- Never ignore the smell of propane or natural gas, even if no detector is sounding an alarm.

GENERATOR MAINTENANCE

LEAVE IT TO THE EXPERTS.

Only a qualified service technician has the training to install, inspect, service, maintain, and repair your generator. Have your generator and propane or natural gas system inspected annually.

DO NOT TRY TO MODIFY OR REPAIR

valves, regulators, connectors, controls, or other generator and cylinder/tank parts. Doing so creates the risk of a gas leak that can result in property damage, serious injury, or death.

FOR NATURAL GAS SYSTEMS, fuel system pipes and hoses must be leak-free and of adequate size to maintain specified supply pressure and volume flow rate under varying generator load conditions.

CO AND YOUR SAFETY

WHAT IS CARBON MONOXIDE (CO)?

You can't taste or smell CO, but it is a very dangerous gas. High levels of CO can come from engine exhaust fumes, appliances that are not operating correctly, or from a venting system or chimney that becomes blocked.

CO CAN BE DEADLY! High levels of CO can make you dizzy or sick. In extreme cases, CO can cause brain damage or death. Symptoms of CO poisoning include: headache, dizziness, fatigue, shortness of breath, and nausea.



IF YOU SUSPECT CO IS PRESENT, ACT IMMEDIATELY!

1. If you or a family member shows physical symptoms of CO poisoning, get everyone out of the area and call 911 or your local fire department.
2. If it is safe to do so, turn off any appliances you suspect may be releasing CO.

3. If no one has symptoms, but you suspect that CO is present, call your propane retailer, the gas company, or a qualified service technician to check CO levels and your propane or natural gas equipment.

CO DETECTORS CAN IMPROVE SAFETY. For an extra measure of safety, consider installing a CO detector (not included) listed by UL on each level of your home.

TO HELP REDUCE THE RISK OF CO POISONING:

- Have a qualified service technician check your propane appliances and venting systems annually, preferably before the heating season.
- Install UL-listed CO detectors on every level of your home.
- Never use a gas oven or range-top burners to provide space heating.
- Do not use the generator indoors or in any enclosed space or in any other area or situation that will allow carbon monoxide to accumulate.
- Never use a barbecue grill (propane or charcoal) indoors for cooking or heating.
- Regularly check your appliance exhaust vents for blockage.

RUNNING OUT OF GAS



DON'T RUN OUT OF GAS. SERIOUS SAFETY HAZARDS, INCLUDING FIRE OR EXPLOSION, CAN RESULT.

- If an appliance valve or a gas line is left open, a leak could occur when the system is recharged with propane.
- **A LEAK CHECK IS REQUIRED.** In many states, a propane retailer or a qualified service technician must perform a leak check of your propane system before turning on the gas.

Table of Contents

Specifications	3	Maintenance	28
Safety	4	Troubleshooting	33
Setup	12	Parts List and Diagram	37
Operation	18	Warranties	40

Specifications

Generator	AC Output (Gasoline)	120/240VAC, 60Hz, 83.3/41.7A, 1 Phase 10000 Running Watts 13000 Maximum Starting Watts
	AC Output (LPG/Propane)	120/240VAC, 60Hz, 75.8/37.9A, 1 Phase 9100 Running Watts 12000 Maximum Starting Watts
	AC Output (Natural Gas)	120/240VAC, 60Hz, 65.0/32.5A, 1 Phase 7800 Running Watts 10000 Maximum Starting Watts
	Receptacles	4x 120VAC, 20A GFCI 1x 120VAC, 30A Twist Lock L5-30R 1x 120/240VAC, 30A Twist Lock L14-30R 1x 120/240VAC, 50A NEMA 14-50R
Displacement		458cc
Compression Ratio		8.8:1
Engine Type		Horizontal Single Cylinder, 4-stroke, OHV
Cooling System		Forced air cooled
Fuel	Type	87+ octane, stabilizer-treated unleaded gasoline; LPG/Propane; or Natural Gas
	Gasoline Tank	10.7 Gallon / 40.5 Liter
	LPG/Propane Tank	40 lb tank minimum
	Natural Gas	Fuel Rating: 1000 BTU/cu ft Minimum Fuel Supply Size: 1/2" Supply Pressure: 5~9 WC (1.2-2.24 KPa) Maximum Flow Rate: 125000 BTU/hr
Engine Oil	Type SAE	10W-30
	Capacity	1.3 Quart / 1.2 Liter
Run Time @ 50% Load with full gasoline tank		12.1 hours
Run Time @ 50% Load with 100 lb LPG tank		16 hours
Sound Level at 23 feet, 50% load		78.5 dB(A)
Bore x Stroke		90mm x 72mm
Spark Plug	Type	LG / Torch F7RTJC or equivalent
	Gap	0.031"–0.039"
Valve Clearance	Intake	0.002"–0.004"
	Exhaust	0.002"–0.004"
Engine Speed		3600 RPM
Electric Start Battery		12V–14Ah Lead-Acid Non-Spillable
Remote Control Battery		3V CR2032
Internal Battery		3V CR2032 Contains non-replaceable batteries
Battery Charger	Input: 100–240VAC, 50/60Hz, 0.5A Max • Output: 14VDC, 0.8A Cable Length: 5.9 feet	







The emissions control system for this Engine is warranted for standards set by the U.S. Environmental Protection Agency. For warranty information, refer to the last pages of this manual.

In reference to the remote: Changes or modifications not expressly approved by Harbor Freight Tools could void the user's authority to operate the equipment. FCC ID: 2BBOR-QJ003

WARNING SYMBOLS AND DEFINITIONS

	This is the safety alert symbol. It is used to alert you to potential personal injury hazards. Obey all safety messages that follow this symbol to avoid possible injury or death.
⚠ DANGER	Indicates a hazardous situation which, if not avoided, will result in death or serious injury.
⚠ WARNING	Indicates a hazardous situation which, if not avoided, could result in death or serious injury.
⚠ CAUTION	Indicates a hazardous situation which, if not avoided, could result in minor or moderate injury.
NOTICE CAUTION	Addresses practices not related to personal injury.

Symbol Definitions

Symbol	Property or Statement	Symbol	Property or Statement
RPM	Revolutions Per Minute		WARNING marking concerning Risk of Respiratory Injury. Operate engine OUTSIDE and far away from windows, doors, and vents.
HP	Horsepower		WARNING marking concerning Risk of Fire while handling fuel. Do not smoke while handling fuel.
	WARNING marking concerning Risk of Eye Injury. Wear ANSI-approved safety goggles with side shields.		WARNING marking concerning Risk of Fire. Do not refuel while operating. Keep flammable objects away from engine.
	Read the manual before set-up and/or use.		WARNING: Contains coin battery.
	WARNING marking concerning Risk of Hearing Loss. Wear hearing protection.		

IMPORTANT SAFETY INSTRUCTIONS



WARNING! Read all instructions.

Failure to follow all instructions listed below may result in fire, serious injury and/or DEATH.

The warnings and precautions discussed in this manual cannot cover all possible conditions and situations that may occur. It must be understood by the operator that common sense and caution are factors which cannot be built into this product, but must be supplied by the operator.

SAVE THESE INSTRUCTIONS

Setup Precautions

1. This unit is to be installed so that access is restricted to only qualified service personnel who have been instructed of the reasons for the restrictions applied to the location and about any precautions that must be taken. Access shall be through the use of a special tool, or lock and key, or other means of security and shall be controlled by the authority responsible for the location.
2. LPG/Propane and Natural Gas systems must be installed and used in strict conformance with NFPA 58 (Liquefied Petroleum Gas Code), NFPA 54 (National Fuel Gas Code), manufacturer's recommendations, and all relevant local, state, and federal codes and regulations.
3. LPG/Propane, Natural Gas, and Gasoline fuel and fumes are flammable, and potentially explosive. Use proper fuel storage and handling procedures. Do not store fuel or other flammable materials nearby.
4. Fire and explosion hazard. Never use a gas container, LPG/Propane connector hose, LPG/Propane tank, Natural Gas connector hose, or any other fuel item that appears to be damaged.
5. Fire and explosion hazard. Only use approved LPG/Propane tanks with an Overfilling Prevention Device (OPD) valve. Keep the tank in a vertical position with the valve on top and placed at ground level on a flat surface. Do not allow tanks to be near any heat source. When transporting and storing, turn the propane tank valve to the fully closed position and disconnect the tank. Make sure to always cover the generator inlet and tank outlet with protective plastic caps.
6. Connect LPG/Propane tank using provided attachment kit only. Kit includes 1.5 meter (4.9 ft) hose. Place tank as far away from Generator as hose allows and away from engine exhaust. Do not place tank above Generator.
7. Connect to Natural Gas source using PREDATOR® 1/2" NG Quick Connect Hose Kit only, item 70491 (not included). Kit includes 7.6 meter (25 ft) Hose. Do not use NG Hose with any other appliances.
8. Fire and explosion hazard. If there is a strong smell of Propane or Natural Gas while operating the generator, fully close the LPG/Propane tank valve or NG shutoff valve and shut down the Generator immediately. Once the LPG/NG is off, use soapy water to check for leaks on the hose and connections on the tank valve and the generator. Do not smoke or light a cigarette or check for leaks using any open flame source such as a match or lighter. If a leak is found, contact a qualified technician to inspect and repair the LPG or NG system before using the generator.
9. Install carbon monoxide alarm(s) with battery backup (not included) in nearby buildings according to manufacturer's instructions.
10. Have multiple ABC class fire extinguishers nearby.
11. Operation of this equipment may create sparks that can start fires around dry vegetation. A spark arrestor may be required. The operator should contact local fire agencies for laws or regulations relating to fire prevention requirements.
12. Set up and use only on a flat, level, well-ventilated surface.
13. All connections and conduits from the Generator to the load must only be installed by trained and licensed electricians, and in compliance with all relevant local, state, and federal electrical codes and standards, and other regulations where applicable.
14. Connections for standby power to a building electrical system must be made by a qualified electrician. The connection must isolate the Generator power from utility power, and must comply with all applicable laws and electrical codes.
15. A transfer switch should be installed by a licensed electrician in compliance with all applicable laws and electrical codes.
16. Wear ANSI-approved safety goggles, heavy-duty work gloves, and dust mask/respirator during set up.
17. Use only lubricants and fuel recommended in the Specifications chart of this manual.
18. Improper connections to a building electrical system can allow electrical current from the Generator to backfeed into the utility lines. Such backfeed may electrocute utility company workers or others who contact the lines during a power outage, and the Generator may explode, burn, or cause fires when utility power is restored. Consult the utility company and a qualified electrician if intending to use the Generator for back up power.
19. Do not operate the Generator before grounding. The Generator must be earth-grounded in accordance with all relevant electrical codes and standards before operation.

Operating Precautions

SAFETY

1.  **CARBON MONOXIDE HAZARD**
Using a generator indoors **CAN KILL YOU IN MINUTES**. Generator exhaust contains carbon monoxide. This is a poison you cannot see or smell.

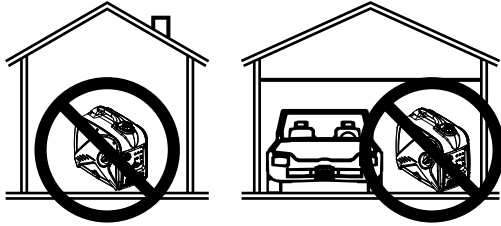

NEVER use inside a home or garage, EVEN IF doors and windows are open.

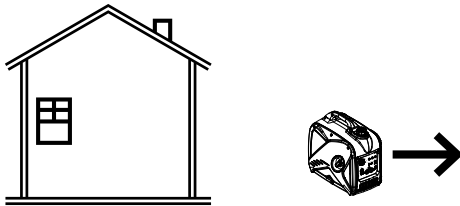

Only use OUTSIDE and far away from windows, doors, and vents.



Do not use in trailers, truck beds, or tents.

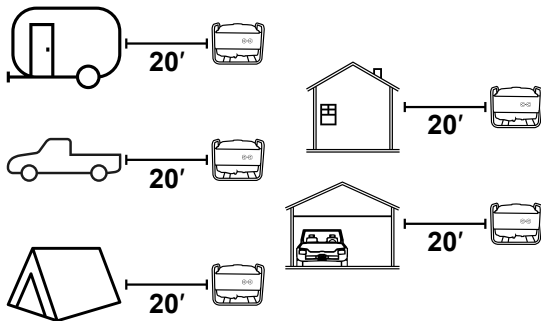

Use at least 20 feet away from people, animals, and structures with exhaust pointed away.

2. **CARBON MONOXIDE SHUTOFF**
DANGER! TO PREVENT SERIOUS INJURY AND DEATH FROM CARBON MONOXIDE INHALATION:
The Carbon Monoxide sensor is an additional layer of protection only. Do not use the Generator in any area or situation that will allow carbon monoxide to accumulate.

- **FLASHING RED LIGHT:**
Dangerous levels of carbon monoxide gas have built up and generator will shutoff. Leave immediately until area has aired out. Move Generator to well-ventilated area before operation.
- **FLASHING YELLOW LIGHT:**
Carbon monoxide sensor malfunction. Sensor needs service. Do not use the Generator until the sensor is working properly. For technical questions, please call 1-800-444-3353.

NOTE: Yellow light flashes once after starting to indicate passing self-check and is functioning normally.

Carbon Monoxide sensor must only be serviced by qualified technician to restore it to original settings. Do not modify or tamper with the Carbon Monoxide sensor. Not following these instructions can result in death or serious injury due to Carbon Monoxide sensor malfunction.

3. Generator will produce carbon monoxide when burning gasoline, LPG, or NG.
4. Never use a generator indoors, including in garages, basements, crawl spaces and sheds. Opening doors and windows or using fans will NOT prevent carbon monoxide build up in the home.
5. When using generators, keep them outdoors and far away from open doors, windows, and vents to avoid toxic levels of carbon monoxide from building up indoors.
6. If you start to feel sick, dizzy, or weak while using a generator, get to fresh air right away. The carbon monoxide from generators can quickly lead to full incapacitation and death.
7. LPG/Propane and Natural Gas are highly flammable and explosive.
8. Flammable gas under pressure can cause a fire or explosion if ignited.
9. LPG/Propane can settle in low places because it is heavier than air.
10. LPG/Propane and Natural Gas have a distinctive odor added to help detect potential leaks. This odor can diminish over time or due to other factors.
11. Keep LPG/Propane tanks in an upright position.

SETUP

OPERATION

MAINTENANCE

12. When exchanging LPG/Propane tanks, be sure the tank valve is the same type.
13. In case of a LPG/Propane or Natural Gas fire, do not attempt to extinguish unless the fuel supply can be shut off safely.
14. LPG/Propane will burn the skin. Prevent skin contact at all times.
15. Keep the LPG/Propane tank, LPG hose, and Natural Gas hose away from engine exhaust.
16. Keep children away from the equipment, especially while it is operating.
17. Fire Hazard! Do not fill gas tank while engine is running. Do not operate if gasoline has been spilled. Clean spilled gasoline before starting engine. Do not operate near pilot light or open flame.
18. Do not touch engine during use. Let engine cool down after use.
19. Never store fuel or other flammable materials near the engine.
20. If the plugged in product operates abnormally or unusually slow, immediately stop using the generator as a power source. Read and adhere to the instruction manual of the product to be powered to make sure that it can be safely and efficiently powered by a portable generator.
21. Before connecting an appliance or power cord to the generator: Make sure that it is in good working order. Faulty appliances or power cords can create a potential for electrical shock.
22. Do not exceed the running wattage of the generator. Make sure that the total electrical rating of all of the tools or appliances plugged into the generator at the same time does not exceed that of the generator. Check that the startup surge will not be beyond the limit of the generator.
23. Do not overload the generator. Even a slight overload may lead to premature generator failure and a substantial overload will trip the circuit breaker.
24. Do not attempt to connect or disconnect load connections while standing in water, or on wet or soggy ground.
25. Do not touch electrically energized parts of the generator and interconnecting cables or conductors with any part of the body, or with any non-insulated conductive object.
26. Connect the generator only to a load that is compatible with the electrical characteristics and running wattage of the generator.
27. Insulate all connections and disconnected wires.
28. **GFCI PRECAUTIONS**
Test Ground Fault Circuit Interrupter (GFCI) receptacles before each use as follows:
 - a. Disconnect all devices from the Generator.
 - b. Start the engine.
 - c. Press Test button on receptacle to trip the GFCI device.
 - d. The Reset button should extend, cutting off electricity to the receptacle.
 - e. If above test fails, do not use receptacle until it is repaired or replaced.
 - f. Press Reset button in for use.
 Refer to *Grounding* on page 12.
29. Guard against electric shock. Prevent body contact with grounded surfaces such as pipes, radiators, ranges, and refrigerators.
30. Only use a suitable means of transport and lifting devices with sufficient weight bearing capacity when transporting the generator.
31. Secure the generator on transport vehicles to prevent it from rolling, slipping, and tilting.
32. Industrial applications must follow OSHA requirements.
33. Do not leave the generator unattended when it is running. Turn off the generator (and remove safety keys, if available) before leaving the work area.
34. The generator can produce high noise levels. Prolonged exposure to noise levels above 85 dBA is hazardous to hearing. Wear ear protection when operating the generator or when working nearby while it is operating.
35. Wear ANSI-approved safety glasses and hearing protection during use.
36. People with pacemakers should consult their physician(s) before use. Electromagnetic fields in close proximity to a heart pacemaker could cause pacemaker interference or pacemaker failure. Caution is necessary when near the engine's magneto or recoil starter.
37. Use only accessories that are recommended by Harbor Freight Tools for your model. Accessories that may be suitable for one piece of equipment may become hazardous when used on another piece of equipment.
38. Do not operate in explosive atmospheres, such as in the presence of flammable liquids, gases, or dust. Gasoline-powered engines may ignite the dust or fumes.
39. Stay alert, watch what you are doing and use common sense when operating this generator. Do not use while tired or under the influence of drugs, alcohol or medication.

40. Dress properly. Do not wear loose clothing or jewelry. Keep hair, clothing and gloves away from moving parts. Loose clothes, jewelry or long hair can be caught in moving parts.
41. Parts, especially exhaust system components, get very hot during use. Stay clear of hot parts.
42. Keep the stop/start remote control away from children. Do not place in tight spaces with other objects that may actuate the remote buttons and send an undesired start signal to the generator.
43. Do not cover the generator during operation.
44. Keep the generator and surrounding area clean at all times.
45. Do not smoke, or allow sparks, flames, or other sources of ignition around the equipment, especially when refuelling.
46. Use the equipment, accessories, etc., in accordance with these instructions and in the manner intended for the particular type of equipment, taking into account the working conditions and the work to be performed. Use of the equipment for operations different from those intended could result in a hazardous situation.
47. Do not operate the equipment with known leaks in the engine's fuel system.
48. When spills of fuel or oil occur, they must be cleaned up immediately. Dispose of fluids and cleaning materials as per any local, state, or federal codes and regulations. Store oil rags in a bottom-ventilated, covered, metal container.
49. Keep hands and feet away from moving parts. Do not reach over or across equipment while operating.
50. Before use, check for misalignment or binding of moving parts, breakage of parts, and any other condition that may affect the equipment's operation. **If damaged, have the equipment serviced before using.** Many accidents are caused by poorly maintained equipment.
51. Use the correct equipment for the application. Do not modify the equipment and do not use the equipment for a purpose for which it is not intended.
52. Extension Cord - Make sure your extension cord is in good condition. When using an extension cord, be sure to use one heavy enough to carry the current your product will draw. An undersized extension cord will cause a drop in line voltage resulting in loss of power and overheating.

The table below shows the correct cord size to use depending on cord length and nameplate ampere rating. If in doubt, use the next heavier gauge. The smaller the gauge number, the heavier the cord.

RECOMMENDED MINIMUM WIRE GAUGE FOR EXTENSION CORDS					
CURRENT (AMPS)	Load @ 120V (WATTS)	Load @ 240V (WATTS)	20 ~ 50 ft	50 ~ 75 ft	75 ~ 100 ft
2	240	480	18 AWG		
4	480	960	18 AWG		16 AWG
6	720	1440	18 AWG	16 AWG	14 AWG
8	960	1920	16 AWG		12 AWG
10	1200	2400	16 AWG	14 AWG	12 AWG
15	1800	3600	14 AWG	12 AWG	10 AWG
20	2400	4800	12 AWG	10 AWG	
25	3000	6000	12 AWG	10 AWG	8 AWG
30	3600	7200	10 AWG	8 AWG	
35	4200	8400	8 AWG	6 AWG	
40	4800	9600	6 AWG		
45	5400	10,800	6 AWG	4 AWG	

Do not use extension cords less than 20 feet in length.

Battery Charger/Maintainer Precautions

1. Do not expose Battery Charger/Maintainer to rain or snow.
2. Use of an attachment not recommended or sold by the Battery Charger/Maintainer manufacturer may result in a risk of fire, electric shock, or injury to persons.
3. To reduce risk of damage to electric plug and cord, pull by plug rather than cord when disconnecting Charger/Maintainer.
4. Do not operate Charger/Maintainer with damaged cord or plug – replace the cord or plug immediately.
5. Do not operate Charger/Maintainer if it has received a sharp blow, been dropped, or otherwise damaged in any way; take it to a qualified serviceman.
6. Do not disassemble Charger/Maintainer – take it to a qualified technician when service or repair is required. Incorrect reassembly may result in a risk of electric shock or fire.
7. To reduce risk of electric shock, unplug Charger/Maintainer from outlet before attempting any maintenance or cleaning.
8. Locate Charger/Maintainer as far away from Generator as power cord permits.
9. Maintain labels and nameplates on the Charger/Maintainer. These carry important safety information. If unreadable or missing, contact Harbor Freight Tools for a replacement.
10. Unplug the Battery Charger/Maintainer from its electrical outlet before connecting its power cord to the Generator, or performing any inspection, maintenance, or cleaning procedures.
11. Do not use Charger/Maintainer while tired or under the influence of drugs, alcohol or medication.

Service Precautions

SAFETY

1. **Before service, maintenance, or cleaning:**
 - a. **Unplug all devices from the Generator.**
 - b. **Push the Engine/Battery Switch to the "STOP" (OFF) position.**
 - c. **Turn the Fuel Selector Switch to the "STORAGE" position.**
 - d. **Allow the engine to completely cool.**
 - e. **Then, remove the spark plug cap from the spark plug.**

SETUP

2. Keep all safety guards in place and in proper working order. Safety guards include muffler, air cleaner, mechanical guards, and heat shields, among other guards.
3. Make sure the Engine/Battery Switch is in its "STOP" position before moving the Generator and before performing any service, maintenance, or cleaning procedures on the unit.

OPERATION

4. **Keep all electrical equipment clean and dry.** Replace any wiring where the insulation is cracked, cut, abraded, or otherwise degraded. Replace terminals that are worn, discolored, or corroded. Keep terminals clean and tight.
5. **Do not alter or adjust any part of the equipment or its engine that is sealed by the manufacturer or distributor. Only a qualified service technician may adjust parts that may increase or decrease governed engine speed.**
6. Wear ANSI-approved safety goggles, heavy-duty work gloves, and dust mask/respirator during service.
7. Maintain labels and nameplates on the equipment. These carry important information. If unreadable or missing, contact Harbor Freight Tools for a replacement.

MAINTENANCE

8. Have the equipment serviced by a qualified repair person using only identical replacement parts. This will ensure that the safety of the equipment is maintained. Do not attempt any service or maintenance procedures not explained in this manual or any procedures that you are uncertain about your ability to perform safely or correctly.
9. Store equipment out of the reach of children.
10. Follow scheduled engine and equipment maintenance.

GFCI Protection:

This Generator is equipped with two 3-Prong, duplex 120V ground fault circuit interrupter (GFCI) receptacles. These outlets provide additional protection from the risk of electric shock. Should replacement of the receptacles become necessary, use only identical replacement parts that include GFCI protection.

Refueling:

1. Turn off the generator before refilling the fuel tank. Do not refill the fuel tank while the engine is running or hot.
2. Do not smoke, or allow sparks, flames, or other sources of ignition around the equipment, especially when refueling.
3. **TO PREVENT FUEL LEAKAGE AND FIRE HAZARD, Do Not fill fuel tank to the top.** Leave a little room for the fuel to expand as needed.
4. Refuel in a well-ventilated area only.
5. Wipe up any spilled fuel and allow excess to evaporate before starting engine. **To prevent FIRE, do not start the engine while the smell of fuel hangs in the air.**
6. Do not connect LPG/Propane or NG fuel sources to the Generator while operating with gasoline. Shut down Generator and allow to cool before connecting alternate fuel type.

PREDATOR®

Button/Coin Battery Warnings

⚠ WARNING	
<ul style="list-style-type: none">• INGESTION HAZARD: This product contains a button cell or coin battery.• DEATH or serious injury can occur if ingested.• A swallowed button cell or coin battery can cause Internal Chemical Burns in as little as 2 hours.• KEEP new and used batteries OUT OF REACH OF CHILDREN• Seek immediate medical attention if a battery is suspected to be swallowed or inserted inside any part of the body.	

 This symbol means:
INGESTION HAZARD: This product contains a button cell or coin battery.

1. Remove and immediately recycle or dispose of used batteries according to local regulations and keep away from children. Do NOT dispose of batteries in household trash or incinerate.
2. Even used batteries may cause severe injury or death.
3. Call a local poison control center for treatment information.
4. Non-rechargeable batteries are not to be recharged.
5. Do not force discharge, recharge, disassemble, heat above 140°F or incinerate. Doing so may result in injury due to venting, leakage or explosion resulting in chemical burns.
6. Ensure the batteries are installed correctly according to polarity (+ and -).
7. Do not mix old and new batteries, different brands or types of batteries, such as alkaline, carbon-zinc, or rechargeable batteries.
8. Remove and immediately recycle or dispose of batteries from equipment not used for an extended period of time according to local regulations.
9. Always completely secure the battery compartment. If the battery compartment does not close securely, stop using the product, remove the batteries, and keep them away from children.



SAVE THESE INSTRUCTIONS.

PREDATOR®

Set Up/Assembly



Read the **ENTIRE IMPORTANT SAFETY INFORMATION** section at the beginning of this manual including all text under subheadings therein before set up or use of this product.

WARNING

TO PREVENT SERIOUS INJURY AND FIRE: Operate only with proper spark arrestor installed.



Operation of this equipment may create sparks that can start fires around dry vegetation. A spark arrestor may be required. The operator should contact local fire agencies for laws or regulations relating to fire prevention requirements.

At high altitudes, the engine's carburetor, governor, and any other parts that control the fuel-air ratio will need to be adjusted by a qualified mechanic to allow efficient high-altitude use and to prevent damage to the engine and any other devices used with this product.

Note: For additional information regarding the parts listed in the following pages, refer to the Assembly Diagram near the end of this manual.

NOTICE: This Generator is not intended to power sensitive electronic equipment without the addition of an appropriate line conditioner and surge protector (both not included). **Sensitive electronic equipment includes, but is not limited to, audio/video equipment, some television sets, computers, and printers.** Sensitive electronic equipment should be operated on approved inverter-type generators or pure sine wave generators.

Grounding

The Generator must be properly grounded in accordance with all relevant electrical codes and standards before operation. In many locations, local code will not require this generator to be grounded when used with cord and plug equipment plugged directly into the receptacles on the generator. However, your local regulations may require the generator to be grounded. Contact a licensed electrician or consult local authorities regarding local grounding requirements. If grounding is required, have the unit grounded by a qualified electrician if you are not qualified to do so.

General grounding instructions are as follows:

Use one of the following as the grounding electrode:

Pipe or conduit, minimum 3/4 in. diameter, minimum 8 ft. long. If steel, it must have anti-corrosion coating.

Rod, stainless steel or copper- or zinc-coated steel, minimum 5/8 in. diameter, minimum 8 ft. long.

1. Drive electrode at least 8 ft. vertically into the ground.
 - a. If rock layer prevents vertical entry, drive at an angle not exceeding 45 degrees from vertical.
 - b. If rock layer prevents angle entry, bury electrode in horizontal trench at least 30 in. deep.
2. The upper end of electrode must be protected if above ground level.
3. Connect a #6 AWG grounding wire (not included) from the Grounding Terminal on the Generator Control Panel to the buried electrode.

For additional information on grounding methods, please see the National Electrical Code.

NOTICE: There is a permanent conductor between the portable generator stator winding (Neutral Conductor) and the frame.

12VDC Battery Connection

For the electric start and auto-choke functions, or to operate on LPG or NG fuel, the included 12VDC Battery must be connected and charged before first use.

1. Push Engine/Battery Switch to STOP (OFF) position.
2. Connect the two ends of the Battery Quick Connector together.

Note: The built-in charging circuit charges the Battery while the Engine is running. Turn the Engine/Battery Switch off and use the Battery Charger/Maintainer to keep the Battery charged when the Generator is not in use or in storage. Refer to 12VDC Battery: in *Storage* on page 32.

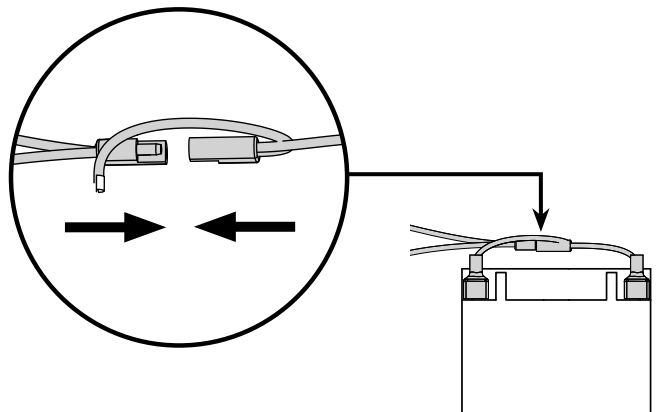

Foot Assembly

The Feet are installed on the air filter side of the Generator.

1. Prepare a set of 4x4 blocks on level ground. With assistance, place the Generator on the blocks.
2. Secure one Foot (168) onto a Foot Bracket (169) using a Hex Bolt (171) and Hex Flange Nut (158). Repeat for other Foot and Bracket.
3. Align studs on Foot Bracket assembly with holes on bottom of Generator frame and secure in place with two Hex Flange Nuts (170). Repeat for other Foot Bracket assembly.

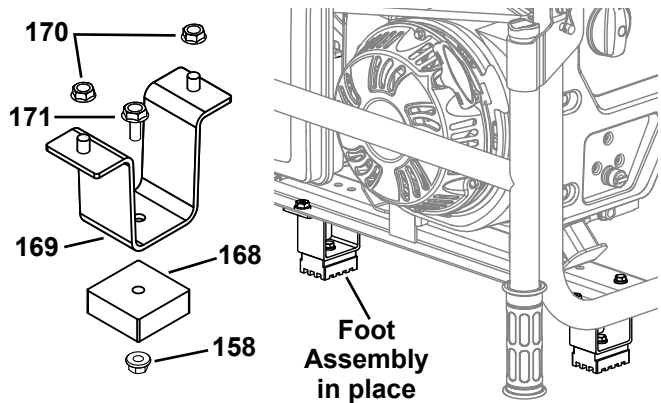

Wheel Assembly

1. Slide one Wheel (174) and two Flat Washers (173) onto a Wheel Axle (172), one Washer on each side of Wheel.
2. Insert the Wheel Axle through the bracket on the bottom of the Generator frame. Place a third Flat Washer onto the Axle and secure all in place with an R-Clip (175).
3. Repeat steps 1 and 2 for other Wheel assembly.

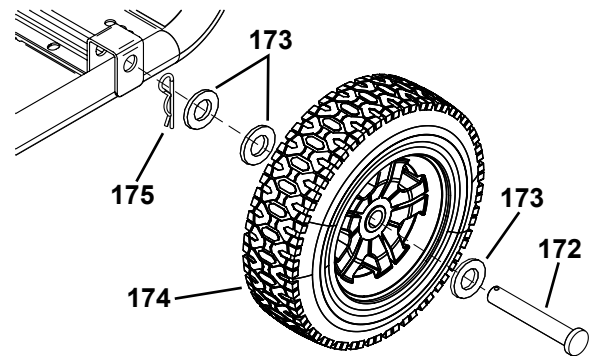

Handle Assembly

The Handle is installed on the air filter side of the Generator.

1. Align the holes in the brackets on the Handle (177) with the holes on the Generator frame.
2. Fasten in place using a Step Bolt (180) and Flange Lock Nut (181), one set on each side of Handle.
3. Remove and discard the yellow shipping clip located on the Handle Release Pin (178).
4. Insert the Locking Pin (183) into the hole on the right side of the Generator frame.

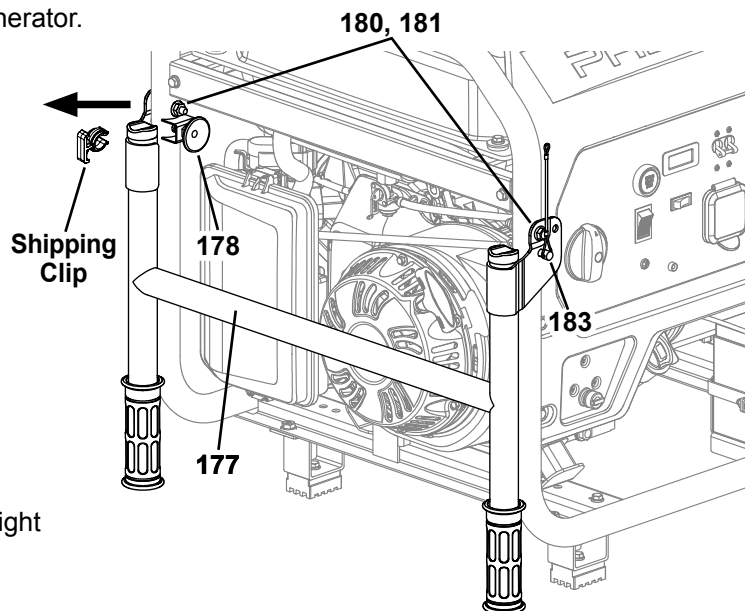

Handle Operation

1. To unfold the Handle for use, first remove the Locking Pin, then pull out the Handle Release Pin and lift the Handle up. With the Handle lifted into position, release the Handle Release Pin, then insert the Locking Pin back into place.
2. To fold the Handle down after use, first remove the Locking Pin, then pull out the Handle Release Pin and push the Handle down. With the Handle in position, release the Handle Release Pin, then insert the Locking Pin back into place.

Components and Controls

SAFETY

SETUP

OPERATION

MAINTENANCE

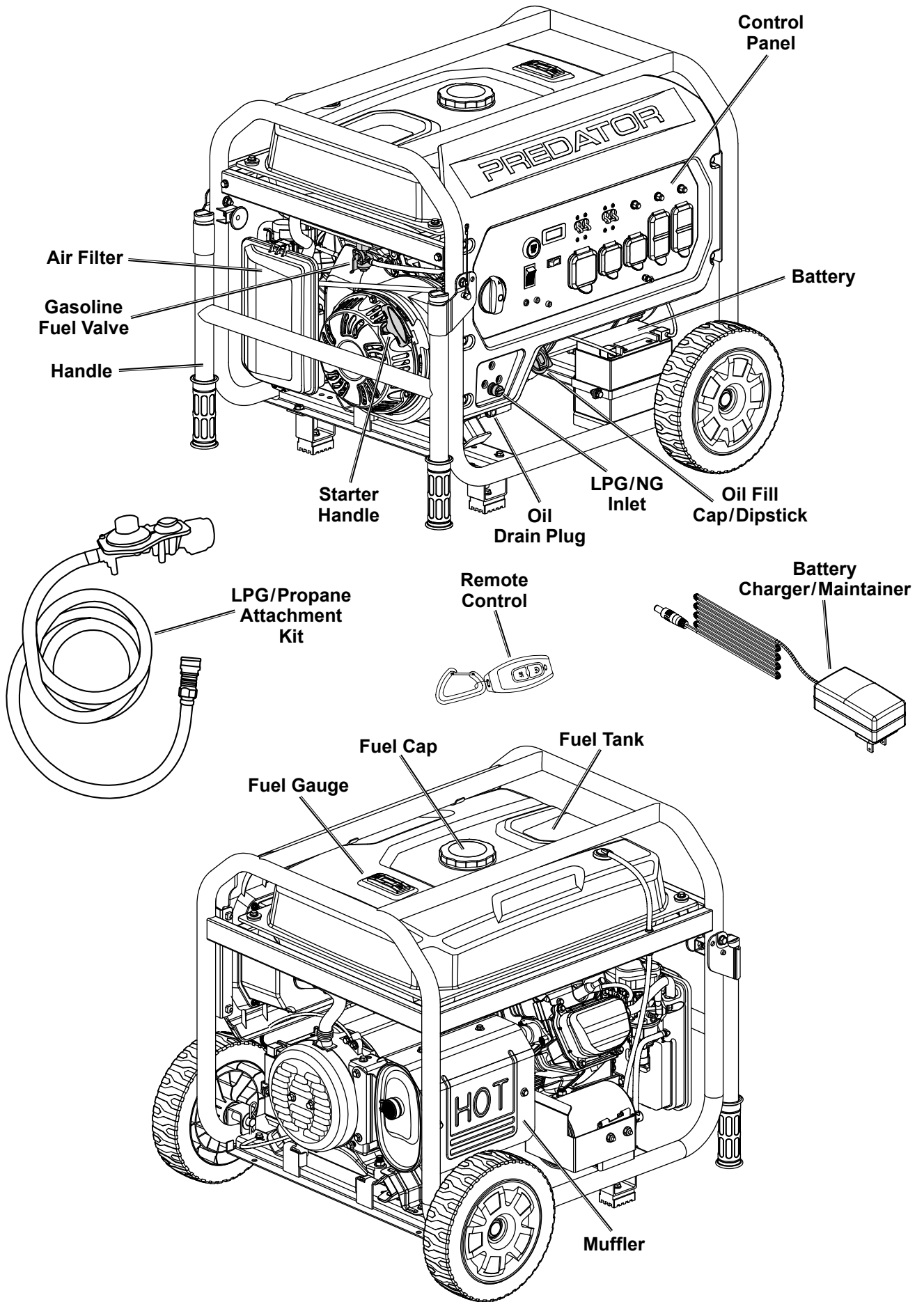

Components and Controls (continued)

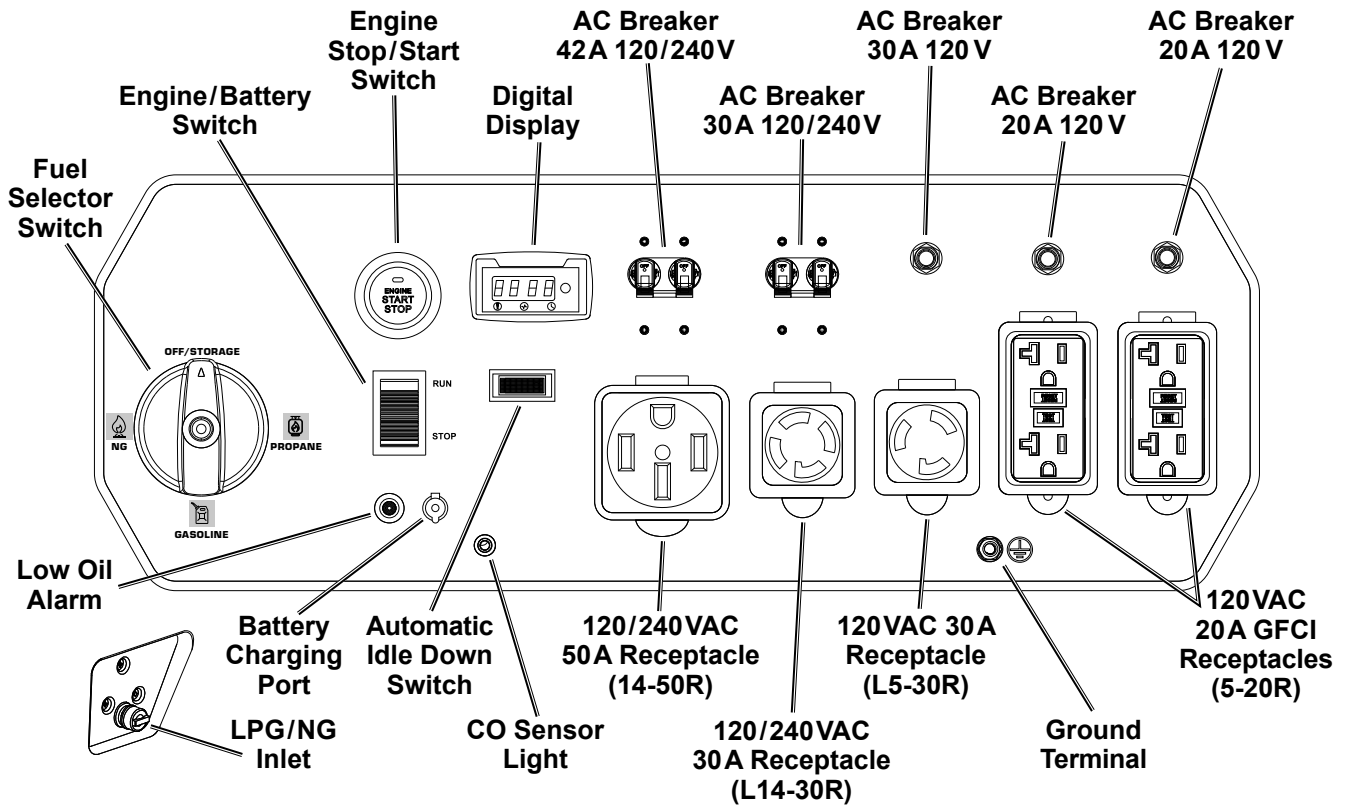

Control Panel

The following are descriptions of the controls on the Control Panel. Your Generator has sockets to power your products with circuit breakers to protect the voltage flow.

1. **Fuel Selector Switch:** Used to select from three fuel types - Gasoline, LPG/Propane, or Natural Gas. Storage position shuts off flow of all fuel types.

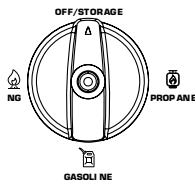

2. **Engine/Battery Switch:** Push to RUN position to enable starting remotely, electrically, or manually.

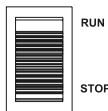

3. **Engine Stop/Start Switch:** Used to start and stop the Engine.



4. **Digital Display:** Press the Mode Button to cycle through the Display's functions:
 - Voltage (Displays U + voltage reading. Example: "U240")
 - Frequency (Displays F + frequency reading. Ex.: "F60")
 - Current session runtime
 - Total (accumulated) runtime

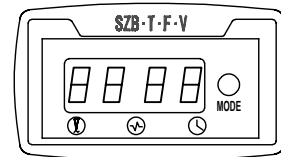

Note: Every 50 hours, a blinking maintenance reminder will appear on the screen (P050, P100, P150, etc.) See Page 28 for maintenance schedule. To clear a maintenance reminder, press and hold the Mode Button for 5 seconds.

5. **Automatic Idle Down Switch:** Used to turn the Engine Idle function ON or OFF. In ON position Engine speed (and frequency) is reduced when no load is detected. Engine runs at full speed (and frequency) when load above 75W is applied.

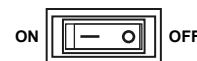

Notice: Turn Automatic Idle Switch OFF when connected load is less than 300W.

6. **CO Sensor Light:** Flashing red light indicates dangerous levels of carbon monoxide gas have built up. Flashing yellow light indicates a carbon monoxide sensor malfunction. Refer to *Carbon Monoxide Shutoff* on page 25 for further information.



7. **AC Receptacles:** The Generator contains several AC Receptacles to power tools and equipment.

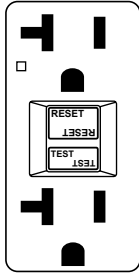

- a. 3-Prong, duplex
120 volt GFCI receptacle
(NEMA 5-20R)

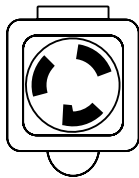

- b. 3-Prong, twistlock,
120 volt 30A receptacle
(NEMA L5-30R)



- c. 4-Prong, twistlock,
120/240 volt 30A receptacle
(NEMA L14-30R)

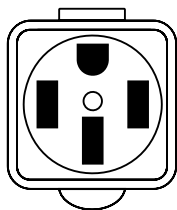

- d. 4-Prong, 120/240 volt,
50A receptacle
(NEMA 14-50R)

⚠ WARNING! TO PREVENT SERIOUS INJURY:
Connect tools and equipment only to the Receptacle (120 volt or 240 volt) that is compatible with the electrical characteristics and rated capacities of the tools and equipment being used.

8. **Circuit Breakers:** The circuit breaker protects the Generator from overloading. The rating of the breaker and the load it protects are marked near the breaker. Should any of the Circuit Breakers trip, the Generator will stop the electricity output. If this happens, unplug all loads from the Generator. Then, turn the tripped Circuit Breaker to ON and re-attach loads gradually. **Note:** For push-type Circuit Breakers allow a few minutes for cool-down before resetting.



9. **Low Oil Alarm:** If the Engine oil level is too low, the LOW OIL ALARM light turns on and the Engine will automatically shut off.



10. **LPG/Propane and Natural Gas Connector:**
Used to connect LPG/NG hose to Generator.

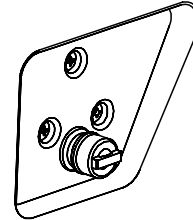

11. **Grounding Terminal:** Prior to each use, set up the ground wire (not included) connection to the Grounding Terminal to properly ground the Generator. Refer to *Grounding* on page 12 for instructions on grounding the Generator.



12. **Battery Charging Port:** Used to charge the 12VDC Generator Battery using the provided Battery Charger/Maintainer.



High Altitude Operation Above 3000 feet

⚠️WARNING! TO PREVENT SERIOUS INJURY FROM FIRE:

Follow instructions in a well-ventilated area away from ignition sources.

If the Engine is hot from use, shut the engine off and wait for it to cool before proceeding. Do not smoke.

NOTICE: Warranty void if necessary adjustments are not made for high altitude use.

At high altitudes, the engine's carburetor, governor, and any other parts that control the fuel-air ratio will need to be adjusted by a qualified mechanic to allow efficient high-altitude use and to prevent damage to the engine and any other devices used with this product. The fuel system on this engine may be influenced by operation at higher altitudes. Proper operation can be ensured by installing an altitude kit at altitudes higher than 3000 ft. above sea level. At elevations above 8000 ft., the engine may experience decreased performance, even with the proper main jet. Operating this engine without the proper altitude kit installed may increase the engine's emissions and decrease fuel economy and performance. The kit should be installed by a qualified mechanic.

Note: Not all Generator models have a Solenoid. Skip those steps if a Solenoid is not present.

1. Turn off the Engine and close the gasoline Fuel Valve.
2. Turn the Fuel Selector Switch to the STORAGE position.
3. Move Air Cleaner Housing aside to allow access to the Carburetor:
 - a. Remove Air Cleaner Cover.
 - b. Remove foam filter and deflecting plate.
 - c. Remove Nuts to allow Air Cleaner Housing to be moved aside.
4. Place a bowl under the Fuel Cup to catch any spilled fuel.
5. Unthread the screws holding the Solenoid in place.

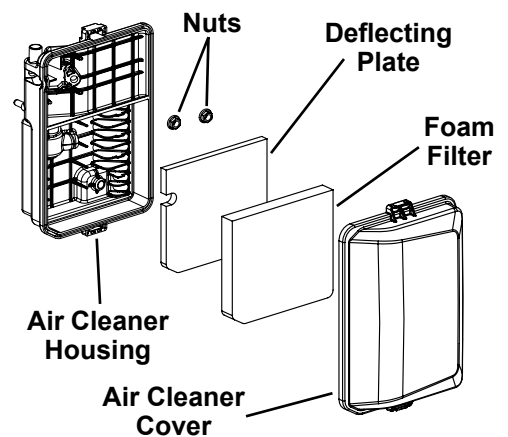

CAUTION! Carburetor bowl may have gas in it which will leak upon removing the Solenoid/Bolt.

6. Disconnect the Solenoid and Solenoid Seal from the Bolt.
7. Unthread the Bolt holding the Fuel Cup.
8. Remove the Bolt, Bolt Seal, Fuel Cup, Fuel Cup Seal and Main Jet from the body of the Carburetor assembly. A carburetor screwdriver (not included) is needed to remove and install the Main Jet.

Note: The mixing tube is held in place by the Main Jet and might fall out when it is removed. If it falls out, replace it in the same orientation before replacing the Main Jet.

9. Replace the Main Jet with the replacement Main Jet needed for your altitude range (part 1a or 2a).

Note: The Fuel Cup Seal and Bolt Seal may be damaged during removal and should be replaced with the new ones from the kit.

10. Replace the Fuel Cup Seal (4a), Fuel Cup, Bolt Seal (3a), and Bolt. Tighten in place.

NOTICE: Do not cross thread bolt when tightening. Finger tighten first and then use a wrench to make sure the bolt is properly threaded.

11. Replace the Solenoid and Solenoid Seal (5a), and tighten in place with screws.
12. Reassemble the Air Cleaner and reattach all hoses to it.
13. Wipe up any spilled fuel and allow excess to evaporate before starting Engine. To prevent FIRE, do not start the Engine while the smell of fuel hangs in the air.

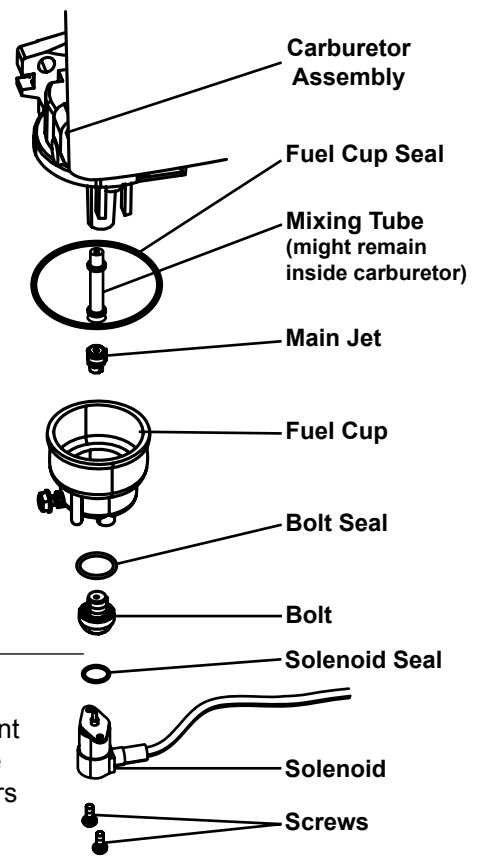

High Altitude Kit Parts List - A

Part	Description	Qty
1a	Main Jet 3000-6000 ft.	1
2a	Main Jet 6000-8000 ft.	1
3a	Bolt Seal	1
4a	Fuel Cup Seal	1
5a	Solenoid Seal	1

Operation

! Read the **ENTIRE IMPORTANT SAFETY INFORMATION** section at the beginning of this manual including all text under subheadings therein before set up or use of this product.

Pre-Start Checks

Only operate the generator outside and at least 20 feet away from people, animals, and structures, with exhaust pointed away. Inspect Engine and Generator looking for damaged, loose, and missing parts before set up and starting. If any problems are found, do not use equipment until fixed properly.

Checking and Filling Engine Oil

NOTICE: Generator is shipped without engine oil. Engine's crankcase **MUST** be filled with oil before first use. Your Warranty is **VOID** if the Engine's crankcase is not properly filled with oil before first use and before each use thereafter. Before each use, check the oil level. Engine will not start with low or no engine oil.

1. Make sure the Engine is stopped and is level.
2. Clean the top of the Oil Fill Cap/Dipstick and the area around it. Remove the Cap/Dipstick by turning it counterclockwise and wipe it off with a clean, lint free rag.
3. Add the appropriate type of oil until the oil level is at the proper level. SAE 10W-30 oil is recommended for general use. The SAE Viscosity Grade chart on page 29 in the *Maintenance* section shows other viscosities to use in different average temperatures.

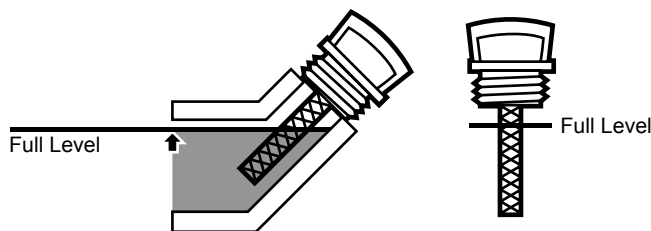

4. Reinsert the Dipstick without threading it in and remove it to check the oil level. The oil level should be up to the edge of the hole as shown.
5. Thread the Oil Fill Cap/Dipstick back in clockwise.

NOTICE: Do not run the engine with too little oil. Engine will shut off if engine oil level is too low.

For Gasoline Operation: Checking and Filling Fuel



! WARNING! TO PREVENT SERIOUS INJURY FROM FIRE:

Fill the fuel tank in a well-ventilated area away from ignition sources. If the Engine is hot from use, shut the Engine off and wait for it to cool before adding fuel. Do not smoke.

1. Clean the Fuel Cap and the area around it.
2. Unscrew and remove the Fuel Cap.
3. Remove the Strainer and remove any dirt and debris. Then replace the Strainer.

Note: Do not use gasoline containing more than 10% ethanol (E10). Do not use E85 ethanol. Add fuel stabilizer to the gasoline or the Warranty is **VOID**.

Note: Do not use gasoline that has been stored in a metal fuel container or a dirty fuel container. It can cause particles to enter the carburetor, affecting Engine performance and/or causing damage.

4. If needed, fill the Fuel Tank to about 1 inch under the fill neck of the Fuel Tank with 87 octane or higher unleaded gasoline that has been treated with a fuel stabilizer additive. Follow fuel stabilizer manufacturer's recommendations for use.
5. Replace the Fuel Cap.
6. Wipe up any spilled fuel and allow excess to evaporate before starting engine. To prevent FIRE, do not start the engine while the smell of fuel hangs in the air.

For LPG Operation: Connecting LPG/Propane Tank



- a. **LPG/Propane and Natural Gas systems must be installed and used in strict conformance with NFPA 58 (Liquefied Petroleum Gas Code), NFPA 54 (National Fuel Gas Code), manufacturer's recommendations, and all relevant local, state, and federal codes and regulations.**
- b. **The LPG/Propane tank capacity must be minimum 40 lb or larger to avoid tank freezing during use. Tank must conform to the standard as listed in Setup Precautions section.**
- c. **Propane tanks that use a liquid withdrawal system cannot be used with this Generator.**
- d. **Verify the re-qualification date on the tank has not expired.**
- e. **Connect LPG/Propane tank using provided attachment kit only. Kit includes 1.5 meter (4.9 ft) Hose. Place tank as far away from Generator as Hose allows and away from engine exhaust. Do not place tank above Generator. Do not use included LPG/Propane Hose with any other appliances.**
- f. **All new tanks or used tanks that have not been plugged or kept closed must be purged of air and moisture by a propane supplier prior to filling.**
- g. **Position the tank so the connection between the tank valve and the LPG/NG Inlet will not cause sharp bends or kinks in the Hose.**
- h. **Inspect the LPG/Propane Hose before every use. Do not use damaged equipment. If damage is detected, have the problem corrected before further use.**



⚠ WARNING! EXPLOSION HAZARD. TO PREVENT SERIOUS INJURY:

Do not start the engine if the smell of LPG/Propane hangs in the air. Close the propane tank valve and disconnect the

LPG/Propane hose from the Generator when not in use.

1. Turn the Generator OFF and place on a flat surface in a well ventilated area.
2. Verify that the propane tank valve is in the fully closed position.
3. Attach the Quick Connect Adapter on the LPG/Propane Hose to the LPG/NG Inlet on the Generator.
4. Remove the safety plug or cap from the propane tank valve.
5. Attach the other end of the Hose to the LPG/Propane connector on the tank. Hand tighten clockwise to a positive stop. To prevent damage, do not use a wrench or tool to tighten the connector.
6. Turn the propane tank valve to the fully open position. Check for leaks by applying soapy water to all connections. Look for bubbles. If bubbles are present at connections, close the propane tank valve and tighten connections. Open the valve and recheck connections. If a leak continues or is not at a connection do not use the Generator. Have the problem corrected before further use.

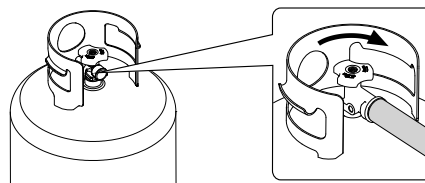

Close Tank Valve

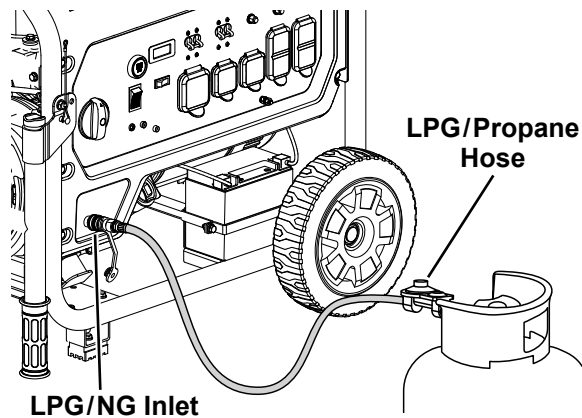

LPG/NG Inlet

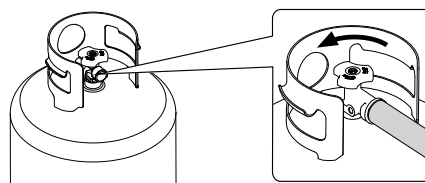

Open Tank Valve

For Natural Gas Operation: Connecting to NG Source



- LPG/Propane and Natural Gas systems must be installed and used in strict conformance with NFPA 58 (Liquefied Petroleum Gas Code), NFPA 54 (National Fuel Gas Code), manufacturer's recommendations, and all relevant local, state, and federal codes and regulations.
- Natural Gas source must meet requirements listed in *Specifications* chart on page 3.
- Connect to Natural Gas source using PREDATOR® 1/2" NG Quick Connect Hose Kit only, item 70491 (not included). Kit includes 7.6 meter (25 ft) Hose. Do not use NG Hose with any other appliances.
- An NG shutoff valve (not included) must be installed before connecting the NG Hose. Do not connect NG Hose directly to the NG source.
- Position the Generator so the connection between the NG shutoff valve and the LPG/NG Inlet will not cause sharp bends or kinks in the Hose.
- Make sure the NG source location and the NG Hose allow the Generator to be located at least 20 feet from any occupied spaces.
- Inspect the NG Hose before every use. Do not use damaged equipment. If damage is detected, have the problem corrected before further use.



⚠ WARNING! EXPLOSION HAZARD. TO PREVENT SERIOUS INJURY:

Do not start the engine if the smell of Natural Gas hangs in the air. Close the NG shutoff valve and disconnect the NG hose from the Generator when not in use.

- Turn the Generator OFF and place on a flat surface in a well ventilated area.
- Verify that the NG shutoff valve is in the fully closed position.
- Attach the Quick Connect Adapter on the NG Hose to the LPG/NG Inlet on the Generator.
- Connect the Coupling from the NG Hose Kit to the shutoff valve, then connect the NG Hose assembly to Coupling.

Note: Natural gas pipe sealant, joint compound, or the proper type of PTFE tape must be used **ONLY** for the connection from the Coupling to the shutoff valve.

- Turn the NG shutoff valve to the fully open position. Check for leaks by applying soapy water to all connections and joints. Look for bubbles. If bubbles are present at connections, close the shutoff valve and tighten connections. Open the valve and recheck connections. If a leak continues or is not at a connection do not use the Generator. Have the problem corrected before further use.

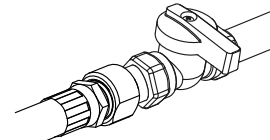

Close NG Shutoff Valve

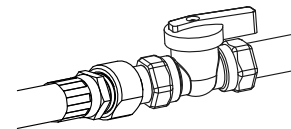
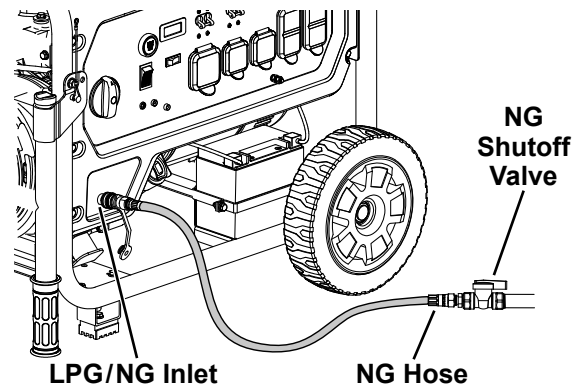

Open NG Shutoff Valve

Remote Start

The Start/Stop Remote Control will operate up to approximately 100 feet in distance from the Generator. The distance at which the Remote will function may be adversely affected by obstructions between the Generator and the Remote Control.

Note: The operational range of the Remote Control may decrease as the battery in the Remote become depleted.

Remote replacement battery: CR2032

Reprogramming the Start/Stop Remote Control

If the Start/Stop Remote Control is replaced or needs to be paired to the generator, follow this procedure:

1. Push the Engine/Battery Switch to the RUN (ON) position.
2. Push and hold the Engine Start/Stop Switch for 10 seconds until the Switch Indicator Light flashes green, then release the Switch.

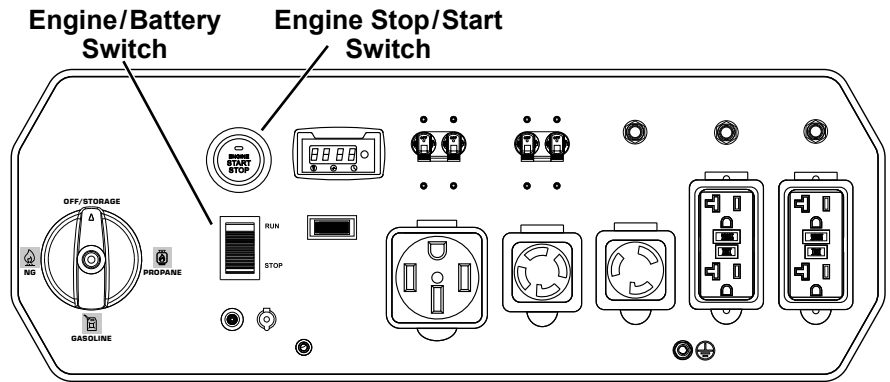

3. Push the 2x button on the Stop/Start Remote Control. It will pair with Generator and the Switch Indicator Light on the Generator will stop flashing.

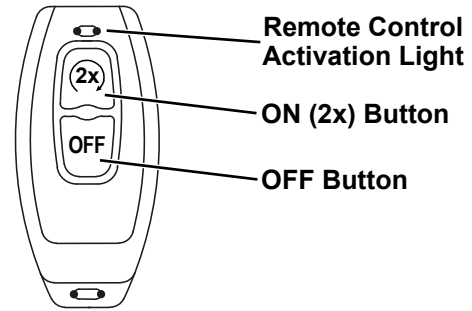

Fuel Selector Switch

Turn the Fuel Selector Switch on the Control Panel to the desired fuel setting.

Note: The Engine is equipped with a safety solenoid valve — Battery must be connected and charged to allow operation with LPG or NG fuel.

1. To operate the Generator on gasoline turn the Fuel Selector Switch to the GAS setting.
2. To operate the Generator on LPG/Propane turn the Fuel Selector Switch to the PROPANE setting.
3. To operate the Generator on Natural Gas turn the Fuel Selector Switch to the NG setting.
4. When the Generator is not in use turn the Fuel Selector Switch to the OFF/STORAGE position to turn off all fuel flow to Engine.

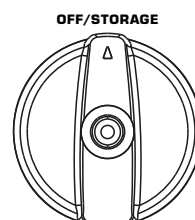
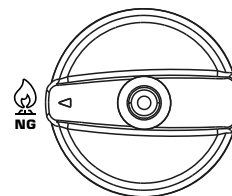
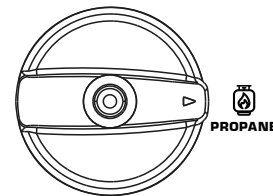
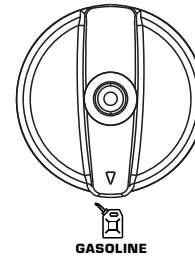

Starting the Engine – Gasoline Operation

Before Starting the Engine



- a. Inspect the generator and engine.
- b. Disconnect all electrical loads from the generator.
- c. Fill the engine with the proper amount and type of both stabilizer-treated unleaded gasoline and oil.

1. Open gasoline Fuel Valve.

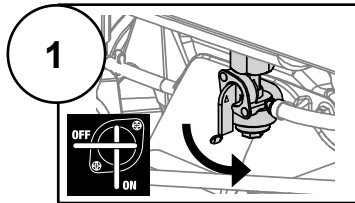

2. Turn the Fuel Selector Switch to the GASOLINE setting.

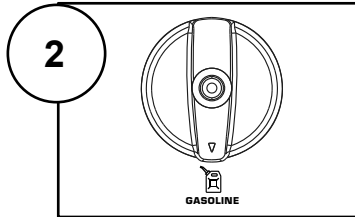

3. Push the Engine/Battery Switch to the RUN position.

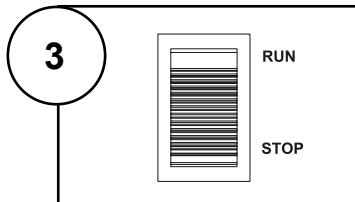

Select a starting method:

4. **Manual Start:** Grip the Starter Handle of the Engine loosely and pull it slowly several times to allow gasoline to flow into the Engine's carburetor. Then pull the Starter Handle gently until resistance is felt. Allow Cable to retract fully and then pull it quickly. Repeat until the Engine starts. Do not let the Starter Handle snap back against the housing. Hold it as it recoils so it doesn't hit the housing.
5. **Remote Start:** Slowly press and release the 2x Button on the Stop/Start Remote Control twice.
Note: If a CO shutoff event has occurred the remote start capability will be disabled until the Generator Engine has been restarted by another method.
6. **Electric Start:** Slowly press and release the Engine Start/Stop Switch twice.

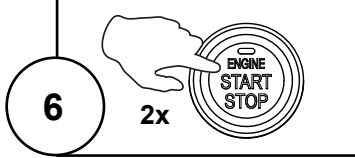
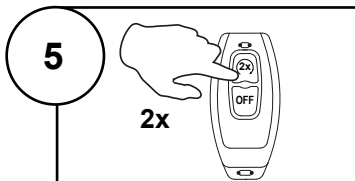
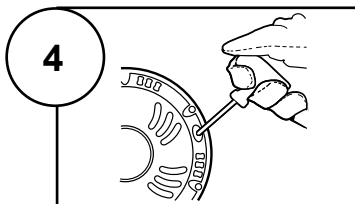

Note: The Engine is equipped with an auto-choke system which requires the battery to be charged to operate. If battery is dead, use the mechanical choke override located above the carburetor to manually choke and unchoke the Engine and start the Engine manually.

If engine does not start:

- **Check engine oil level.**
Engine will not start with low or no engine oil.
- **Check spark arrestor cleanliness.**
Engine will not start if spark arrestor is clogged.

IMPORTANT: Allow the Engine to run at no load for five minutes after each start-up so that the Engine can stabilize.

Starting the Engine – LPG/Propane Operation

Before Starting the Engine



- Inspect the generator and engine.
- Disconnect all electrical loads from the generator.
- Make sure the LPG/Propane hose is correctly connected to the generator and propane tank.
- Make sure Battery is connected and charged.

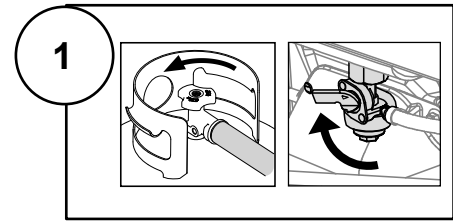

- Fully open the valve on the LPG/Propane tank. Close gasoline Fuel Valve if open.
- Turn the Fuel Selector Switch to the PROPANE setting.
- Push the Engine/Battery Switch to the RUN position.

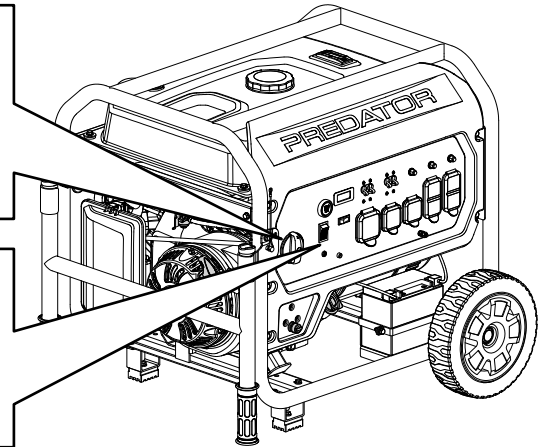
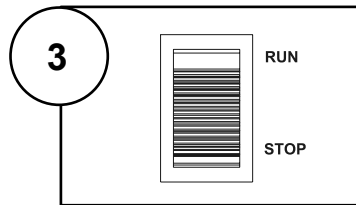
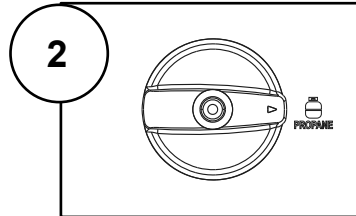

Select a starting method:

- Manual Start:** Grip the Starter Handle of the Engine loosely and pull it slowly several times to allow gasoline to flow into the Engine's carburetor. Then pull the Starter Handle gently until resistance is felt. Allow Cable to retract fully and then pull it quickly. Repeat until the Engine starts. Do not let the Starter Handle snap back against the housing. Hold it as it recoils so it doesn't hit the housing.
- Remote Start:** Slowly press and release the 2x Button on the Stop/Start Remote Control twice.
Note: If a CO shutoff event has occurred the remote start capability will be disabled until the Generator Engine has been restarted by another method.
- Electric Start:** Slowly press and release the Engine Start/Stop Switch twice.

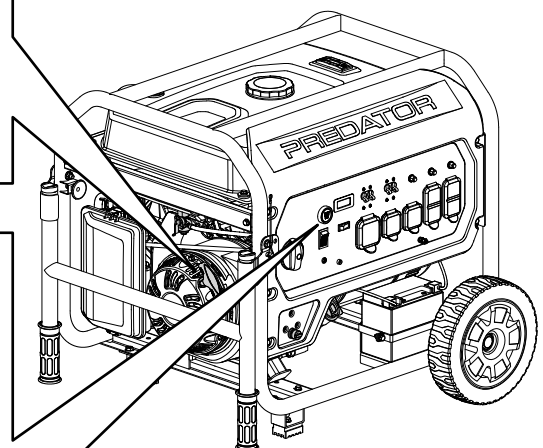
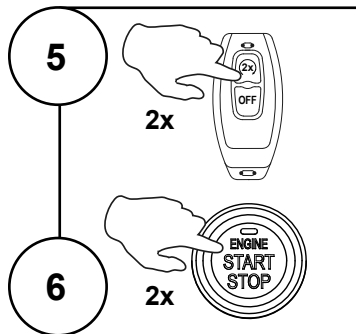
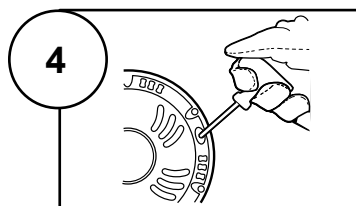

Note: The Engine is equipped with an auto-choke system and a safety solenoid valve for LPG operation which both require the battery to be charged to operate. If battery is dead, use the mechanical choke override located above the carburetor to manually choke and unchoke the Engine. Start the Engine manually using gasoline, then switch to LPG after Engine is started. Refer to *Switching Fuel Sources* on page 25.

If engine does not start:

- Check engine oil level.**
Engine will not start with low or no engine oil.
- Check spark arrestor cleanliness.**
Engine will not start if spark arrestor is clogged.

IMPORTANT: Allow the Engine to run at no load for five minutes after each start-up so that the Engine can stabilize.

Starting the Engine – Natural Gas Operation

SAFETY

SETUP

OPERATION

MAINTENANCE

Before Starting the Engine



- Inspect the generator and engine.
- Disconnect all electrical loads from the generator.
- Make sure the NG hose is correctly connected to the generator and the NG source.
- Make sure Battery is connected and charged.

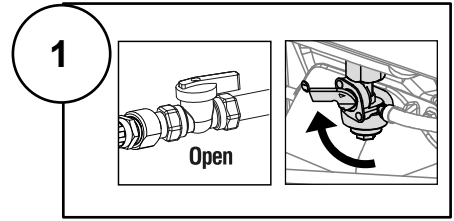

1. Fully open the NG shutoff valve. Close gasoline Fuel Valve if open.
2. Turn the Fuel Selector Switch to the NG setting.

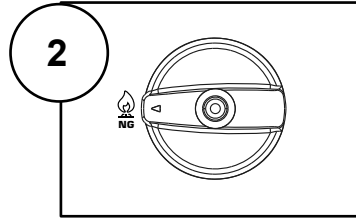

3. Push the Engine/Battery Switch to the RUN position.

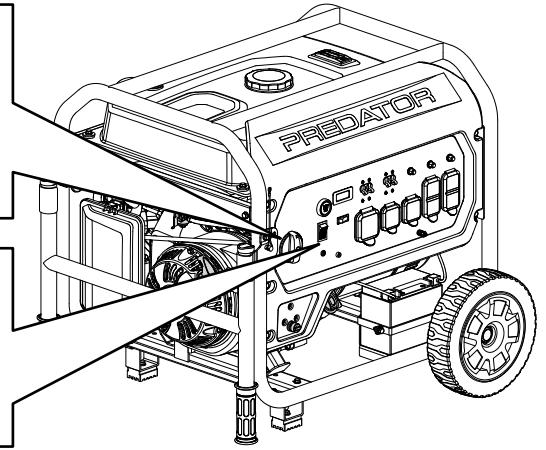
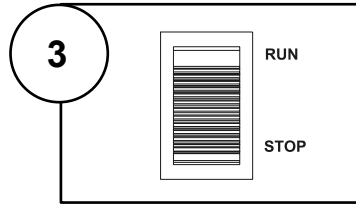

Select a starting method:

4. **Manual Start:** Grip the Starter Handle of the Engine loosely and pull it slowly several times to allow gasoline to flow into the Engine's carburetor. Then pull the Starter Handle gently until resistance is felt. Allow Cable to retract fully and then pull it quickly. Repeat until the Engine starts. Do not let the Starter Handle snap back against the housing. Hold it as it recoils so it doesn't hit the housing.
5. **Remote Start:** Slowly press and release the 2x Button on the Stop/Start Remote Control twice.
Note: If a CO shutoff event has occurred the remote start capability will be disabled until the Generator Engine has been restarted by another method.
6. **Electric Start:** Slowly press and release the Engine Start/Stop Switch twice.

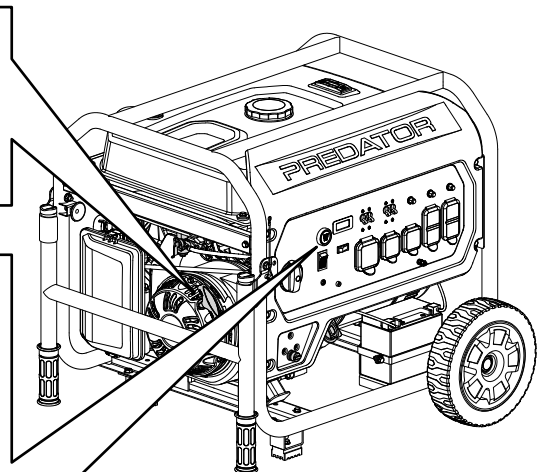
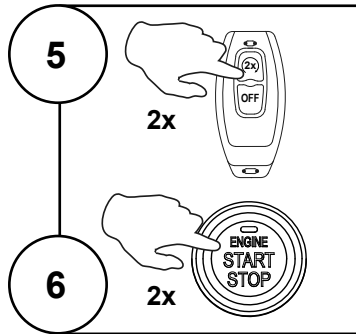
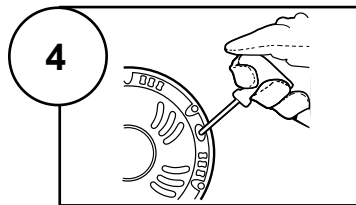

Note: The Engine is equipped with an auto-choke system and a safety solenoid valve for NG operation which both require the battery to be charged to operate. If battery is dead, use the mechanical choke override located above the carburetor to manually choke and unchoke the Engine. Start the Engine manually using gasoline, then switch to NG after Engine is started. Refer to *Switching Fuel Sources* on page 25.

If engine does not start:

- **Check engine oil level.**
Engine will not start with low or no engine oil.
- **Check spark arrestor cleanliness.**
Engine will not start if spark arrestor is clogged.

IMPORTANT: Allow the Engine to run at no load for five minutes after each start-up so that the Engine can stabilize.

Switching Fuel Sources



Fire and explosion hazard. DO NOT add gasoline to the fuel tank or connect a LPG/Propane Hose or Natural Gas hose to the generator while the generator is in operation.

The fuel source can be switched while the Engine is running if a propane tank or natural gas source is connected to the Generator BEFORE operation.

Switching from Gasoline to LPG/Propane or Natural Gas

1. **IMPORTANT: Disconnect all electrical loads from the Generator before switching from one fuel type to another.**
2. Fully open the valve on the LPG/Propane tank or the Natural Gas shutoff valve.
3. Close the gasoline Fuel Valve on the Engine.
4. Turn the Fuel Selector Switch to the PROPANE or NG setting.

Note: When switching from gasoline to LPG/Propane or Natural Gas operation the Engine may run rough for a few seconds while it purges gasoline in the carburetor. If the Engine stops when switching fuel sources, the unit may be restarted using either fuel source.

Switching from LPG/Propane or Natural Gas to Gasoline

1. **IMPORTANT: Disconnect all electrical loads from the Generator before switching from one fuel type to another.**
2. Open the gasoline Fuel Valve on the Engine.
3. Turn the Fuel Selector Switch to the GAS setting.
4. Turn the LPG/Propane tank valve or the Natural Gas shutoff valve to the fully closed position.

Break-in Period

- a. Breaking-in the Engine will help to ensure proper equipment and Engine operation.
- b. The break-in period will last about 30 hours of use.
 - DO NOT exceed 75% of the Generator's running wattage during this period.
 - Change the engine oil after this period.

Under normal operating conditions subsequent maintenance follows the schedule explained in the **MAINTENANCE** section.

CARBON MONOXIDE SHUTOFF

DANGER! TO PREVENT SERIOUS INJURY AND DEATH FROM CARBON MONOXIDE INHALATION: The Carbon Monoxide sensor is an additional layer of protection only. DO NOT USE THE GENERATOR INDOORS OR IN ANY ENCLOSED SPACE OR IN ANY OTHER AREA OR SITUATION THAT WILL ALLOW CARBON MONOXIDE TO ACCUMULATE.

- **FLASHING RED LIGHT:**
Dangerous levels of carbon monoxide gas have built up. Leave immediately until area has aired out. Move Generator to well-ventilated area before operation.
- **FLASHING YELLOW LIGHT:**
Carbon monoxide sensor malfunction. Sensor needs service. Call 1-800-444-3353 as soon as possible. Do not use the Generator until the sensor is working properly.
NOTE: Yellow light flashes once after starting to indicate passing self-check and is functioning normally.

The Carbon Monoxide sensor must only be serviced by a qualified technician to restore it to original settings. Do not modify or tamper with the Carbon Monoxide sensor. Not following these instructions can result in death or serious injury due to Carbon Monoxide sensor malfunction.

Connecting Electrical Loads to the Generator

Calculate Power Draw

Power draw can be calculated by multiplying *volts* and *amps*. The resulting number is *wattage*.

- The total combined load through the outlets on the Generator must not exceed the running power of the unit. Never exceed the running wattage for the Generator or any outlet amperage rating.
- Refer to appliance/tool owner's manuals to determine the wattage of electrical load devices.
- Long power cords and extension cords draw additional power. Keep cord length at a minimum.

WARNING! Never exceed the rated capacity for this Generator, as serious damage to the Generator and/or appliances, tools, and equipment could result from an overload. Starting and running wattage requirements should always be calculated when matching this Generator's wattage capacity to the appliance, tool, or equipment.

NOTICE: Starting and running wattages vary depending on fuel used to operate Generator. Refer to chart:

Fuel	Starting Watts	Running Watts
Gasoline	13,000 Maximum	10,000
LPG/Propane	12,000 Maximum	9100
Natural Gas	10,000 Maximum	7800

Wattage Estimates

Refer to your device documentation for start-up and running wattage requirements. Check nameplate wattages on all loads before connecting to Generator.

Plug the power cord of the 120/240 volt appliance/tool into the appropriate Outlet on the Generator. Plug in appliances from largest to smallest load.

- a. Connect the items that require the most wattage first.
- b. Connect "inductive" load appliances, tools, and equipment next. Inductive loads are small hand tools and some small appliances.
- c. Connect any lights next.
- d. Voltage sensitive appliances, tools, and equipment should be the last to be connected to the Generator. Plug voltage sensitive items such as TVs, DVD players, microwaves, and cordless telephones into a UL® Listed voltage surge protector (not included). Then, connect the surge protector into the Generator.

IMPORTANT! Failure to connect and operate appliances, tools, and equipment in this sequence can cause damage to the Generator, appliances, tools, and equipment and will **void** the Warranty of this Generator.

Note: Do not allow the Generator to completely run out of fuel with devices attached.

A Generator's output may sharply spike as it runs out of fuel, causing damage to attached devices.

Low Oil Indicator

1. If the Engine oil level is too low, the LOW OIL ALARM light turns on and the Engine will automatically shut off.
2. The Engine cannot be restarted until the proper amount of oil has been added. Add the appropriate type of oil until the oil level is at the proper level. SAE 10W-30 oil is recommended for general use.

NOTICE: Do not run the engine with too little oil. Engine will shut off if engine oil level is too low.

Automatic Idle Down Switch

1. Turn the Automatic Idle Switch ON to limit noise and fuel consumption for lighter generator loads. Engine speed (and frequency) are reduced when no load is detected. Engine runs at full speed (and frequency) when load above 75W is applied.

Note: Turn Automatic Idle Switch OFF when connected load is less than 300W.

2. Turn the Automatic Idle Switch OFF to operate Engine at full speed:
 - a. when starting
 - b. when a heavy load is applied

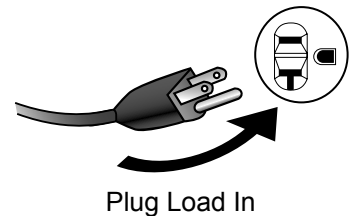

IF ANY CIRCUIT BREAKERS TRIP CHECK THE FOLLOWING:

3. Make sure that **ALL circuit breakers** are reset before starting the Generator again.
4. Adjust the plugs so the loads are shared across outlet circuits.

To achieve rated output from the Generator, distribute loads over outlets.

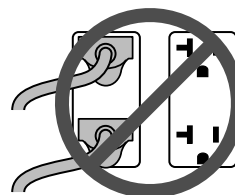

Evenly distributed over outlets:

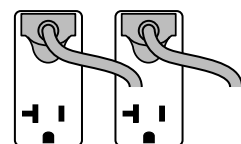

Stopping the Engine

To stop the Engine in an emergency, push the Engine/Battery Switch to STOP.

NOTICE: Generator shutoff under load may damage the Generator and attached equipment.

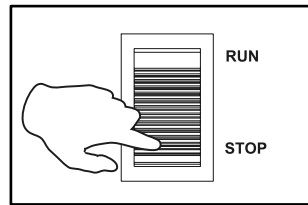

EMERGENCY SHUT OFF

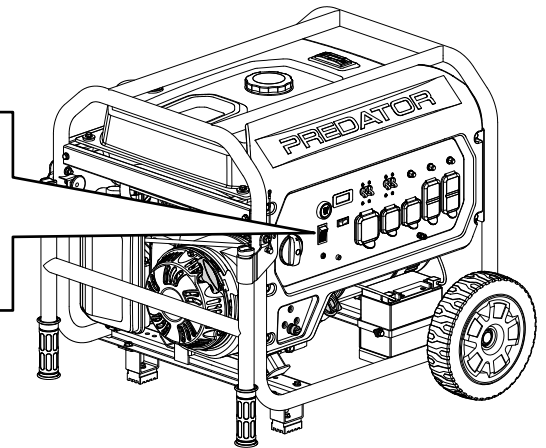

Under normal conditions, use the following procedure to shut off the Generator:

1. Turn all electrical load devices off and unplug them from the Generator.

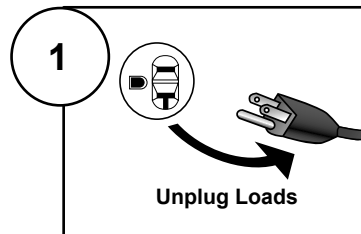

2. Slowly press and release the Engine Start/Stop Switch. Or slowly press and release the OFF button on the Stop/Start Remote Control. Turn the Fuel Selector Switch to the STORAGE position.

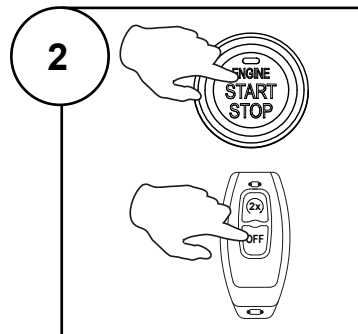

Note: When the Generator is turned OFF using the Stop/Start Switch or Remote Control, the Generator enters standby mode and can be restarted remotely using procedures indicated in starting section. If Generator is not started within 12 hours the Controller shuts down completely to save the battery. Push the Engine/Battery Switch to STOP then RUN to reactivate standby mode.

3. Push the Engine/Battery Switch to the STOP position.

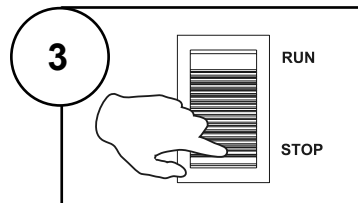

Note: Turn the Engine/Battery Switch off when the Generator is not in use to prevent draining the Battery.

4. If operating on LPG/Propane, turn the propane tank valve to the fully closed position.

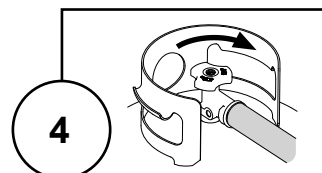

5. If operating on Natural Gas, turn the NG shutoff valve to the closed position.

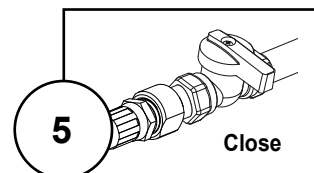

Maintenance

WARNING

TO PREVENT SERIOUS INJURY FROM ACCIDENTAL STARTING:

Push the Engine/Battery Switch of the equipment to the "STOP" (OFF) position, wait for the engine to cool, and disconnect the spark plug cap before performing any inspection, maintenance, or cleaning procedures.

TO PREVENT SERIOUS INJURY FROM EQUIPMENT FAILURE:

Do not use damaged equipment. If abnormal noise, vibration, or excess smoking occurs, have the problem corrected before further use.

Follow all service instructions in this manual. The engine may fail critically if not serviced properly.



Many maintenance procedures, including any not detailed in this manual, will need to be performed by a qualified technician for safety. If you have any doubts about your ability to safely service the equipment or engine, have a qualified technician service the equipment instead.

Cleaning, Maintenance, and Lubrication Schedule

Note: This maintenance schedule is intended solely as a general guide. If performance decreases or if equipment operates unusually, check systems immediately. The maintenance needs of each piece of equipment will differ depending on factors such as duty cycle, temperature, air quality, fuel quality, and other factors.

Note: The following procedures are in addition to the regular checks and maintenance explained as part of the regular operation of the engine and equipment.

Procedure	Before Each Use	Monthly or every 8 hr. of use	Every 3 mo. or 50 hr. of use	Every 6 mo. or 100 hr. of use	Yearly or every 300 hr. of use	Every 2 Years	Page
1. Brush off outside of engine 2. Check engine oil level 3. Check air filter 4. Check LPG/NG hose assembly	✓						
Change engine oil				✓			29
Clean/replace air cleaner			✓*				30
Check and clean spark arrestor				✓			30
Check and clean spark plug				✓			31
1. Check/adjust valve clearance 2. Clean fuel tank, strainer and carburetor 3. Clean carbon build-up from combustion chamber					✓**		-
Replace fuel line if necessary						✓**	-

*Service more frequently when used in dusty areas.

**These items should be serviced by a qualified technician.

Checking and Filling Fuel



⚠️WARNING! TO PREVENT SERIOUS INJURY FROM FIRE:

Fill the fuel tank in a well-ventilated area away from ignition sources. If the engine is hot from use, shut the engine off and wait for it to cool before adding fuel. Do not smoke.

1. Clean the Fuel Cap and the area around it.
2. Unscrew and remove the Fuel Cap.
3. Remove the Strainer and remove any dirt and debris. Then replace the Strainer.

Note: Do not use gasoline containing more than 10% ethanol (E10). Do not use E85 ethanol. Add fuel stabilizer to the gasoline or the Warranty is VOID.

Engine Oil Change

⚠️CAUTION! Oil is very hot during operation and can cause burns. Wait for engine to cool before changing oil.

1. Make sure the Engine is stopped and is level.
2. Close the gasoline Fuel Valve.
3. Place an oil drain pan under the Generator and center under the Oil Drain Plug. Remove the Oil Drain Plug, tilt the Generator slightly to facilitate drainage and wait for oil to drain completely. Recycle used oil.
4. Tilt the Generator and replace the Oil Drain Plug, then set the Generator back down on a level surface.
5. Clean the top of the Oil Fill Cap/Dipstick and the area around it. Remove the Cap/Dipstick, turning it counterclockwise.
6. Add the appropriate type of oil until the oil level is at the proper level. SAE 10W-30 oil is recommended for general use.

Note: Do not thread the dipstick in when checking the oil level.

The SAE Viscosity Grade chart shows other viscosities to use in different average temperatures.

SAE Viscosity Grades

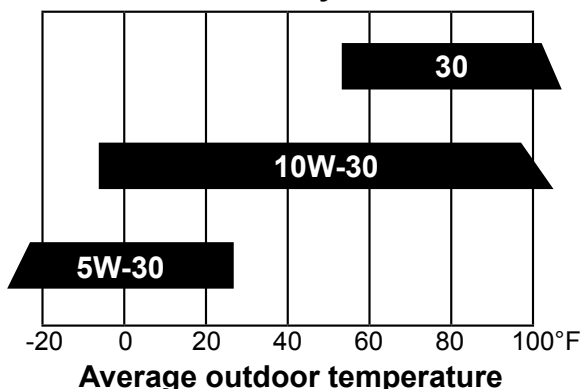

Note: Do not use gasoline that has been stored in a metal fuel container or a dirty fuel container. It can cause particles to enter the carburetor, affecting engine performance and/or causing damage.

4. If needed, fill the Fuel Tank to about 1 inch under the fill neck of the Fuel Tank with 87 octane or higher unleaded gasoline that has been treated with a fuel stabilizer additive. Follow fuel stabilizer manufacturer's recommendations for use.
5. Replace the Fuel Cap.
6. Wipe up any spilled fuel and allow excess to evaporate before starting engine. To prevent FIRE, do not start the engine while the smell of fuel hangs in the air.

Note: Make sure Generator is level when adding oil to prevent overfilling which could cause engine damage.

7. Check the oil level. The oil level should be up to the edge of the hole as shown.

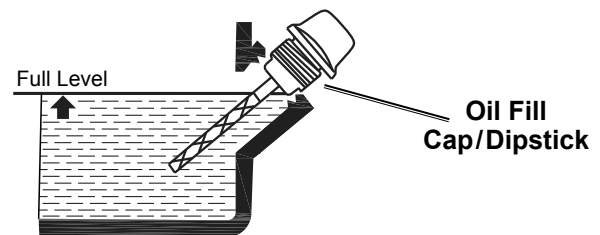

8. Thread the Oil Fill Cap/Dipstick back in clockwise and replace the Access Panel and Oil Drain Door.

NOTICE: Do not run the engine with too little oil. Engine will not start with low or no engine oil.

Air Filter Element Maintenance

1. Remove the Air Filter Cover and the air filter elements and check for dirt. Clean as described below.
2. **Cleaning:**
 - For “paper” filter elements:
To prevent injury from dust and debris, wear ANSI-approved safety goggles, NIOSH-approved dust mask/respirator, and heavy-duty work gloves. In a well-ventilated area away from bystanders, use pressurized air to blow dust out of the air filter.
 - For foam filter elements:
Wash the element in warm water and mild detergent several times. Rinse. Squeeze out excess water and allow it to dry completely. Soak the filter in lightweight oil briefly, then squeeze out the excess oil.
3. Install the cleaned filter.
4. Secure the Air Filter Cover before use.

Spark Arrestor Maintenance**⚠WARNING**

TO PREVENT SERIOUS INJURY AND FIRE: Operate only with proper spark arrestor installed.



Operation of this equipment may create sparks that can start fires around dry vegetation. A spark arrestor may be required. The operator should contact local fire agencies for laws or regulations relating to fire prevention requirements.

1. Allow the Generator to cool completely.
2. Remove Spark Arrestor from end of exhaust.
3. Clean the Spark Arrestor using a wire brush (sold separately). Replace Arrestor if damaged.
4. **WARNING! TO PREVENT SERIOUS INJURY FROM ACCIDENTAL BRUSH FIRE, secure Spark Arrestor back in place immediately after cleaning and before further operation.**

Remote Control Battery Replacement

1. Remove screw(s) and open battery compartment.
2. Remove battery and dispose of properly.
3. Insert battery in correct polarity, close compartment and replace screw(s).

Spark Plug Maintenance

1. Disconnect Spark Plug Cap from end of plug. Clean out debris from around Spark Plug.
2. Use a spark plug wrench to remove the Spark Plug.

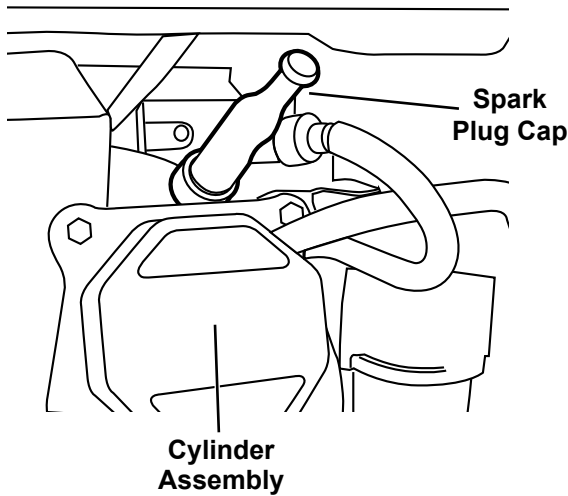

3. Inspect the Spark Plug:
If the electrode is oily, clean it using a clean, dry rag.
If the electrode has deposits on it, polish it using emery paper. If the white insulator is cracked or chipped, the Spark Plug needs to be replaced.

NOTICE: Use only F7RTJC type spark plug or equivalent. Using an incorrect spark plug may damage the engine.

4. When installing a new spark plug, adjust the plug's gap to the specification on the Specifications chart. Do not pry against the electrode—the spark plug can be damaged.
5. Apply anti-seize material to Spark Plug threads. Install the new spark plug or the cleaned spark plug into the engine.

- **Gasket-style:**

Finger-tighten until the gasket contacts the cylinder head, then tighten about 1/2-2/3 turn more.

- **Non-gasket-style:**

Finger-tighten until the plug contacts the cylinder head, then tighten about 1/16 turn more.

NOTICE: Tighten the spark plug properly.

If loose, the spark plug will cause the engine to overheat.

If overtightened, the threads in the engine block will be damaged.

6. Apply dielectric spark plug boot protector (not included) to the end of the spark plug and reattach the cap securely.

Storage

When the equipment is to remain idle for longer than 20 days, prepare the engine for storage as follows:

1. CLEANING:

Wait for engine to cool, then clean engine with dry cloth. **NOTICE: Do not clean using water.** The water will gradually enter the engine and cause damage.

Note: Keep the LPG/NG Inlet covered during cleaning and storage.

2. FUEL:

Gasoline Treatment/Draining the Fuel Tank

To protect the Fuel Tank during storage, fill the Tank with fresh gasoline that has been treated with a fuel stabilizer additive. Follow fuel stabilizer manufacturer's recommendations for use. Refer to *Checking and Filling Fuel* on page 18.

Aged gasoline that has not been treated with stabilizer ahead of time must be safely drained away and not run through the Engine.



⚠ WARNING! TO PREVENT SERIOUS INJURY FROM FIRE:

Fill tank in a well-ventilated area away from ignition sources. If the engine is hot from use, shut the engine off and wait for it to cool before adding fuel. Do not smoke.

Draining the Carburetor

Close the gasoline Fuel Valve and turn the Fuel Selector Switch to the STORAGE position. Place an appropriate container under the Carburetor. Carefully loosen and remove the Drain Bolt from the bottom of the Carburetor Bowl and allow the fuel to drain completely. Replace the Drain Bolt after draining.

WARNING! To prevent serious injury and fire, close the gasoline Fuel Valve before draining the Carburetor.

3. LUBRICATION:

- Change engine oil.
- Clean out area around spark plug. Remove spark plug and pour one tablespoon of engine oil into cylinder through spark plug hole.
- Replace spark plug, but leave spark plug cap disconnected.
- Pull Starter Handle to distribute oil in cylinder. Stop after one or two revolutions when you feel the piston start the compression stroke (when you start to feel resistance).

4. 12VDC BATTERY:

When Generator is not in use or will be stored for extended periods, use the Battery Charger/Maintainer provided to maintain the Battery:

- Plug the Charger/Maintainer power cord into the Battery Charging Port on the Generator.
- Plug the Charger/Maintainer into an electrical outlet.
- Disconnect the Charger/Maintainer before using the Generator.

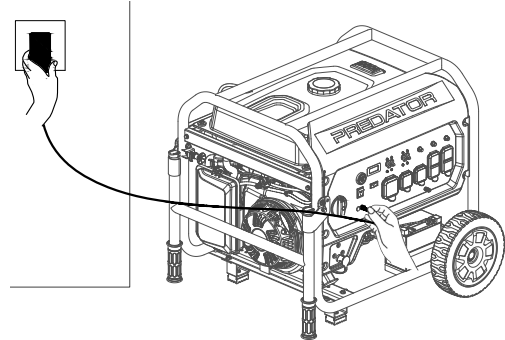

5. STORAGE AREA:

Cover and store in a dry, level, well-ventilated area out of reach of children. Storage area should also be away from ignition sources, such as water heaters, clothes dryers, and furnaces.

NOTICE: During extended storage periods the Engine must be started every 3 months and allowed to run for 15–20 minutes or the Warranty is VOID.

6. AFTER STORAGE:

Before starting the Engine after storage, keep in mind that untreated gasoline will deteriorate quickly. Drain the Fuel Tank and change to fresh fuel if untreated gasoline has been sitting for a month, if treated gasoline has been sitting beyond the fuel stabilizer's recommended time period, or if the Engine does not start.

Troubleshooting

Problem	Possible Causes	Probable Solutions
Engine will not start	FUEL RELATED: <ol style="list-style-type: none"> No fuel in tank or fuel valve closed. No fuel flow. Battery depleted – must be charged and connected to start with LPG or NG fuel. Gasoline with more than 10% ethanol used. (E15, E20, E85, etc.) Low quality or deteriorated, old gasoline. Carburetor not primed. Dirty fuel passageways. Carburetor needle stuck. Fuel can be smelled in the air. Too much fuel in chamber. This can be caused by the carburetor needle sticking. Clogged Fuel Filter. LPG/Propane tank is too small or empty. Improper Natural Gas rating (pressure and flow). 	FUEL RELATED: <ol style="list-style-type: none"> Fill fuel tank with fresh 87+ octane stabilizer-treated unleaded gasoline and open fuel valve. Do not use gasoline with more than 10% ethanol (E15, E20, E85, etc.). Move Fuel Selector Switch to desired fuel type. For LPG/NG fuel, make sure LPG tank valve or NG shutoff valve is fully open. Start Engine manually with gasoline, then switch to LPG or NG fuel while Engine is running. Clean out ethanol rich gasoline from fuel system. Replace components damaged by ethanol. Use fresh 87+ octane stabilizer-treated unleaded gasoline only. Do not use gasoline with more than 10% ethanol (E15, E20, E85, etc.). Use fresh 87+ octane stabilizer-treated unleaded gasoline. Do not use gasoline with more than 10% ethanol (E15, E20, E85, etc.). Pull on Starter Handle to prime. Clean out passageways using fuel additive. Heavy deposits may require further cleaning. Gently tap side of carburetor float chamber with screwdriver handle. Turn Choke to RUN position. Remove spark plug and pull the start handle several times to air out the chamber. Reinstall spark plug and set Choke to START position. Replace Fuel Filter. Use 40 lb. tank or larger; make sure tank is full. Make sure the NG supply system can meet the requirements indicated in the Specification Section .
	IGNITION (SPARK) RELATED: <ol style="list-style-type: none"> Engine/Battery Switch at STOP position. Spark plug cap not connected securely. Spark plug electrode wet or dirty. Incorrect spark plug gap. Spark plug cap broken. Incorrect spark timing or faulty ignition system. 	IGNITION (SPARK) RELATED: <ol style="list-style-type: none"> Push Engine/Battery Switch to RUN position. Connect spark plug cap properly. Clean spark plug. Correct spark plug gap. Replace spark plug cap. Have qualified technician diagnose/repair ignition system.
	COMPRESSION RELATED: <ol style="list-style-type: none"> Cylinder not lubricated. Problem after long storage periods. Loose or broken spark plug. (Hissing noise will occur when trying to start.) Loose cylinder head or damaged head gasket. (Hissing noise will occur when trying to start.) Engine valves or tappets mis-adjusted or stuck. 	COMPRESSION RELATED: <ol style="list-style-type: none"> Pour tablespoon of oil into spark plug hole. Crank engine a few times and try to start again. Tighten spark plug. If that does not work, replace spark plug. If problem persists, may have head gasket problem—see #3. Tighten head. If that does not remedy problem, replace head gasket. Have qualified technician adjust/repair valves and tappets.
	ENGINE OIL RELATED: <ol style="list-style-type: none"> Low engine oil. Engine mounted on slope, triggering low oil shutdown. 	ENGINE OIL RELATED: <ol style="list-style-type: none"> Fill engine oil to proper level. Check engine oil before EVERY use. Operate engine on level surface. Check engine oil level.

SAFETY

SETUP

OPERATION

MAINTENANCE



Follow all safety precautions whenever diagnosing or servicing the generator or engine.

Problem	Possible Causes	Probable Solutions
Engine will not start (continued)	SPARK ARRESTOR RELATED: Spark Arrestor clogged with soot.	SPARK ARRESTOR RELATED: Clean and replace Spark Arrestor.
	ELECTRIC OR REMOTE START RELATED: 1. No battery or defective battery installed. 2. Engine Start/Stop Switch flashes red – Battery is low. 3. Electric start fuse (5A) is blown. 4. Stop/Start Remote Control is not paired with Generator. 5. Generator not picking up Stop/Start Remote Control signal consistently. 6. Engine not restarting remotely after CO shutdown event.	ELECTRIC OR REMOTE START RELATED: 1. Install a new battery. 2. Charge battery with Battery Charger/Maintainer or start Generator manually and allow to run for 5 hours. 3. Replace fuse with similar size fuse. 4. Pair Remote Control to Generator. Refer to page 21. 5. Replace the Remote Control battery; press on Remote Button longer; stay within operational range of Remote. 6. After a CO shutdown event, the remote start capability will be disabled until the Engine has been first restarted non-remotely.
Engine misfires	1. Spark plug cap loose. 2. Incorrect spark plug gap or damaged spark plug. 3. Defective spark plug cap. 4. Old or low quality gasoline. 5. Incorrect compression.	1. Check cap and wire connections. 2. Re-gap or replace spark plug. 3. Replace spark plug cap. 4. Use only fresh 87+ octane stabilizer-treated unleaded gasoline. Do not use gasoline with more than 10% ethanol (E15, E20, E85, etc.). 5. Diagnose and repair compression. Use Engine will not start: COMPRESSION RELATED section.
Engine stops suddenly	1. Carbon Monoxide level high. Red light on Carbon Monoxide Sensor illuminates. 2. CO Sensor Alarm flashes yellow continually shortly after starting. 3. CO Sensor Alarm flashes yellow continually after longer period of operation. 4. Low oil shutdown. 5. Fuel tank empty or full of impure or low quality gasoline. 6. Defective fuel tank cap creating vacuum, preventing fuel flow. 7. Faulty magneto. 8. Disconnected or improperly connected spark plug cap. 9. Unintentional shutdown signal sent from Stop/Start Remote Control. 10. If using Natural Gas: inadequate fuel pressure/flow. 11. If using LPG/Propane: LPG tank empty or LPG tank too small.	1. Leave area immediately and allow area to ventilate thoroughly. Only operate generator outside. 2. Carbon monoxide sensor malfunction. Sensor needs service. Call 1-800-444-3353 as soon as possible. Do not use the Generator until the sensor is working properly. 3. Make sure to operate Generator within rated ambient temperature; maintain minimum 5 ft. clearance from all sides. 4. Fill engine oil to proper level. Check engine oil before EVERY use. 5. Fill fuel tank with fresh 87+ octane stabilizer treated unleaded gasoline. Do not use gasoline with more than 10% ethanol (E15, E20, E85, etc.). 6. Test/replace fuel tank cap. 7. Have qualified technician service magneto. 8. Secure spark plug cap. 9. Store the Remote Control in a safe location and away from children. 10. Ensure NG fuel pressure and flow meet Generator requirements. Refer to <i>Specifications</i> on page 3. 11. Replace empty LPG tank with full tank. Replace small LPG tank with correct tank size. Refer to <i>Specifications</i> on page 3.
Engine stops when under heavy load	1. Dirty air filter 2. Engine running cold.	1. Clean or replace element. 2. Allow engine to warm up prior to operating equipment.



Follow all safety precautions whenever diagnosing or servicing the generator or engine.

Problem	Possible Causes	Probable Solutions
Engine knocks	<ol style="list-style-type: none"> 1. Old or low quality gasoline. 2. Engine overloaded. 3. Incorrect spark timing, deposit buildup, worn engine, or other mechanical problems. 	<ol style="list-style-type: none"> 1. Fill fuel tank with fresh 87+ octane stabilizer-treated unleaded gasoline. Do not use gasoline with more than 10% ethanol (E15, E20, E85, etc.). 2. Do not exceed equipment's load rating. 3. Have qualified technician diagnose and service engine.
Engine backfires	<ol style="list-style-type: none"> 1. Impure or low quality gasoline. 2. Engine too cold. 3. Intake valve stuck or overheated engine. 4. Incorrect timing. 	<ol style="list-style-type: none"> 1. Fill fuel tank with fresh 87+ octane stabilizer-treated unleaded gasoline. Do not use gasoline with more than 10% ethanol (E15, E20, E85, etc.). 2. Use cold weather fuel and oil additives to prevent backfiring. 3. Have qualified technician diagnose and service engine. 4. Check engine timing.
Attached device doesn't have power	<ol style="list-style-type: none"> 1. Device not plugged in properly. 2. Circuit Breaker tripped. 3. GFCI activated. 4. Product needs service. 	<ol style="list-style-type: none"> 1. Turn off and unplug the device, then plug it back in again and turn on. 2. Turn off and unplug device, reset Circuit Breaker, plug in device and turn on. 3. Turn off and unplug device. Test GFCI receptacle. If functioning properly reset GFCI, plug in device and turn on. 4. Have product repaired.
Attached device begins to operate abnormally	<ol style="list-style-type: none"> 1. Problem with device. 2. Rated load capacity exceeded. 	<ol style="list-style-type: none"> 1. Immediately unplug device. Have device repaired by a qualified technician, or replace device. 2. Lower the number of items plugged into the Generator to stay within the rated capacity, or use a more powerful generator.



Follow all safety precautions whenever diagnosing or servicing the generator or engine.

PLEASE READ THE FOLLOWING CAREFULLY

THE MANUFACTURER AND/OR DISTRIBUTOR HAS PROVIDED THE PARTS LISTS AND ASSEMBLY DIAGRAMS IN THIS MANUAL AS A REFERENCE TOOL ONLY. NEITHER THE MANUFACTURER OR DISTRIBUTOR MAKES ANY REPRESENTATION OR WARRANTY OF ANY KIND TO THE BUYER THAT HE OR SHE IS QUALIFIED TO MAKE ANY REPAIRS TO THE PRODUCT, OR THAT HE OR SHE IS QUALIFIED TO REPLACE ANY PARTS OF THE PRODUCT. IN FACT, THE MANUFACTURER AND/OR DISTRIBUTOR EXPRESSLY STATES THAT ALL REPAIRS AND PARTS REPLACEMENTS SHOULD BE UNDERTAKEN BY CERTIFIED AND LICENSED TECHNICIANS, AND NOT BY THE BUYER. THE BUYER ASSUMES ALL RISK AND LIABILITY ARISING OUT OF HIS OR HER REPAIRS TO THE ORIGINAL PRODUCT OR REPLACEMENT PARTS THERETO, OR ARISING OUT OF HIS OR HER INSTALLATION OF REPLACEMENT PARTS THERETO.

Record Product's Serial Number Here: _____

Note: If product has no serial number, record month and year of purchase instead.

Note: Some parts are listed and shown for illustration purposes only, and are not available individually as replacement parts. Specify UPC 193175546814 when ordering parts.

Parts List and Diagram

Parts List

Part	Description	Qty
1	Hex Socket Flange Face Bolt - Small Series	4
2	Cylinder Head Cover Subassembly	1
3	Cylinder Head Cover Gasket	1
4	Stop Detent	1
5	Breather Tube	1
6	Pipe Clamp	2
7	Inner Cylinder Head Cover	1
8	Gasket	1
9	Valve Rocker Subassembly	2
10	Rocker Shaft Subassembly	2
11	Hex Socket Flange Face Bolt - Small Series	3
12	Cylinder Head Cover Pin Limit Plate	1
13	Valve Rotator	2
14	Valve Lock Clamp	4
15	Valve Spring Seat	2
16	Valve Spring	2
17	Seal Guide	1
18	Cylinder Head Bolt	4
19	Cylinder Head Subassembly	1
20	Exhaust Pipe	1
21	Type 1 Nut	2
22	Muffler Gasket	1
23	Stud Bolt	2
24	Spark Plug	1
25	Cylinder Head Gasket	1
26	Position Pin - Type A	2
27	Valve Set	1
28	Valve Lifter Subassembly	2
29	Valve Tappet	2
30	Piston Ring Assembly	1
31	Piston	1
32	Connecting Rod	1
33	Piston Pin	1
34	Piston Pin Clip	2
35	Temperature Sensor	1
36	Hex Socket Flange Face Bolt - Small Series	1
37	Cylinder Body Shroud	1
38	Flat Washer	2
39	Hex Socket Flange Face Bolt - Small Series	2
40	Crankcase Air Deflector	1
41	Oil Seal	1
42	Hex Socket Flange Face Bolt - Small Series	2
43	Starting Motor Assembly	1
44	Drain Plug Bolt	2
45	Wire Clip	3
46	Rubber Plug	1
47	Crankcase Subassembly	1
48	Deep Groove Ball Bearing - P6	1
49	Crankshaft Assembly	1
50	Balancing Shaft	1
51	Camshaft Assembly	1
52	Engine Oil Sensor	1
53	Hex Socket Flange Face Bolt - Small Series	2
54	Flange Nut	1
55	Position Pin - Type A	2
56	Crankcase Gasket	1
57	Deep Groove Ball Bearing - P6	1

Part	Description	Qty
58	Deep Groove Ball Bearing - P53	1
59	Oil Dipstick Subassembly	1
60	Crankcase Cover	1
61	Hex Socket Flange Face Bolt - Small Series	9
62	Oil Seal	1
63	Pipe Clamp	2
64	Shroud	1
65	Hex Socket Flange Face Bolt - Small Series	5
66	Recoil Starter Assembly	1
67	Ignition Coil	1
68	Hex Socket Flange Face Bolt - Small Series	2
69	Flywheel Nut	1
70	Starter Pulley	1
71	Impeller	1
72	Hex Socket Flange Face Bolt - Small Series	1
73	Charge Coil Clamp	1
74	Flywheel Subassembly	1
75	Hex Socket Flange Face Bolt - Small Series	4
76	Charge Coil Subassembly	1
77	Throttle Bottom Plate	1
78	Hex Socket Flange Face Bolt - Small Series	3
79	Stud Bolt	2
80	Inlet Gasket	1
81	Carburetor Insulator Plate	1
82	Carburetor Seal Gasket	1
83	Carburetor Assembly	1
84	Air Cleaner Seal Gasket	1
85	Pipe Clamp	1
86	Rubber Jacket	1
87	Fuel Tube	1
88	Rubber Jacket	1
89	Hex Socket Flange Face Bolt - Small Series	1
90	Air Cleaner Bracket	1
91	Air Cleaner Assembly	1
92	Flange Nut	2
93	Air Cleaner Element	1
94	Air Duct	1
95	Small Spiral Narrow Band Collar - Type A	1
96	Muffler Gasket	1
97	Hex Socket Flange Face Bolt - Small Series	2
98	Muffler Assembly	1
99	Hex Socket Flange Face Bolt - Small Series	2
100	Muffler Bracket	1
101	Hex Socket Flange Face Bolt - Small Series	2
102	Motor Shroud	1
103	Hex Socket Flange Face Bolt - Small Series	1
104	Stator Nut	2
105	Flat Washer	2
106	Standard Spring Washer	2
107	Motor Assembly	1
108	Carbon Brush Subassembly	1
109	Hex Socket Flange Face Bolt - Small Series	1
110	Terminal Block	1
111	Hex Socket Flange Face Bolt - Small Series	2
112	Stopper	1
113	Motor Support	1
114	Hex Socket Flange Face Bolt - Small Series	1

SAFETY

SETUP

OPERATION

MAINTENANCE

Parts List (continued)

SAFETY

SETUP

OPERATION

MAINTENANCE

Part	Description	Qty
115	Flat Washer	1
116	Stator Bolt	4
117	Rotor Bolt	1
118	Stator Bolt	2
119	Voltage Regulator	1
120	Hex Socket Flange Face Bolt - Small Series	2
121	Motor Tail Cover	1
122	Hex Socket Flange Face Bolt - Small Series	2
123	Band	2
124	Hex Socket Flange Face Bolt - Small Series	2
125	Grounding	1
126	External Teeth Serrated Lock Washer	1
127	Fuel Tank	1
128	Fuel Tank Rubber Sleeve	4
129	Bushing	4
130	Flat Washer	4
131	Hex Socket Flange Face Bolt - Big Series	4
132	Cross Recessed Countersunk Head Screw	2
133	Oil Leveler Assembly	1
134	Fuel Tank Cap	1
135	Fuel Strainer	1
136	One Way Valve	1
137	Carbon Canister Hose	1
138	Flange Nut	2
139	Bracket	1
140	Carbon Canister	1
141	Air Cleaner Hose	1
142	Pipe Clamp	1
143	Protective Rubber Sleeve	2
144	Fuel Cock Assembly	1
145	Pipe Clamp	1
146	Fuel Tube	1
147	Hex Socket Flange Face Bolt - Big Series	4
148	Crosspiece Subassembly	1
149	Wire Clip	2
150	Engine Frame Assembly	1
151	Buffering Pad Support	2
152	Flange Nut - Fin Thread	4
153	Engine Frame Cushion	4
154	Flange Nut	4
155	Bracket	1
156	Hex Socket Flange Face Bolt - Big Series	5
157	Engine Frame Shock Absorption Seat	4
158	Flange Nut	2
159	Hex Socket Flange Face Bolt - Big Series	1
160	Battery Clamp	2
161	Battery	1
162	Thermal Baffle	2
163	Thermal Baffle	1
164	Anode Wire	1
165	Hex Socket Flange Face Bolt - Big Series	1
166	Cathode Wire	1
167	Ground Wire	1
168	Engine Frame Shock Absorption Seat	2
169	Engine Frame Shock Absorption Support	2
170	Flange Nut	4

Part	Description	Qty
171	Hex Socket Flange Face Bolt - Small Series	2
172	Front Wheel Shaft	2
173	Flat Washer	6
174	Wheel	2
175	Cotter Pin	2
176	Handle Sleeve	2
177	Handle Tube Assembly	1
178	Handle Release Pin	1
179	Nut	1
180	Hex Step Bolt	2
181	Type 2 All Metal Hex Lock Nut w/Flange	2
182	End Plug	2
183	Pin Shaft	1
184	Strap	1
185	Flange Nut	4
186	Fuel Cock Assembly	1
187	Small Spiral Narrow Band Collar - Type A	3
188	Air Duct	1
189	Gas Pressure Relief Valve	1
190	Cross-Recessed Pan Head Screw	3
191	Carbon Monoxide Alarm	1
192	Screw	2
193	Flange Nut	6
194	Front Panel	1
195	Knob	1
196	Cross-Recessed Pan Head Screw	1
197	Control Module	1
198	Charger Module	1
199	Hex Socket Flange Face Bolt - Big Series	5
200	Control Panel Subassembly	1
201	Cross-Recessed Pan Head Tapping Screw	4
202	Switch Subassembly	1
203	Starting Switch	1
204	Timer	1
205	Double-Pole Circuit Breaker	1
206	Double-Pole Circuit Breaker	1
207	Overcurrent Protector	3
208	Power Supply Socket Subassembly	2
209	Water Proof Cover	2
210	Grounding Terminal Subassembly	1
211	Power Supply Socket Subassembly	1
212	Rain Cover Receptacle	2
213	Power Supply Socket Subassembly	1
214	Power Supply Socket Subassembly	1
215	Rain Cover Receptacle	1
216	Switch Subassembly	1
217	Oil Alarm Indicator	1
218	CO Indicator Mounting Base	1
219	CO Indicator	1
220	Remote Control Module	1
221	Pipe Clamp	2
222	Band	2
223	Battery Charger/Maintainer	1
224	Remote Control	1
225	LPG/Propane Attachment Kit	1

Assembly Diagram

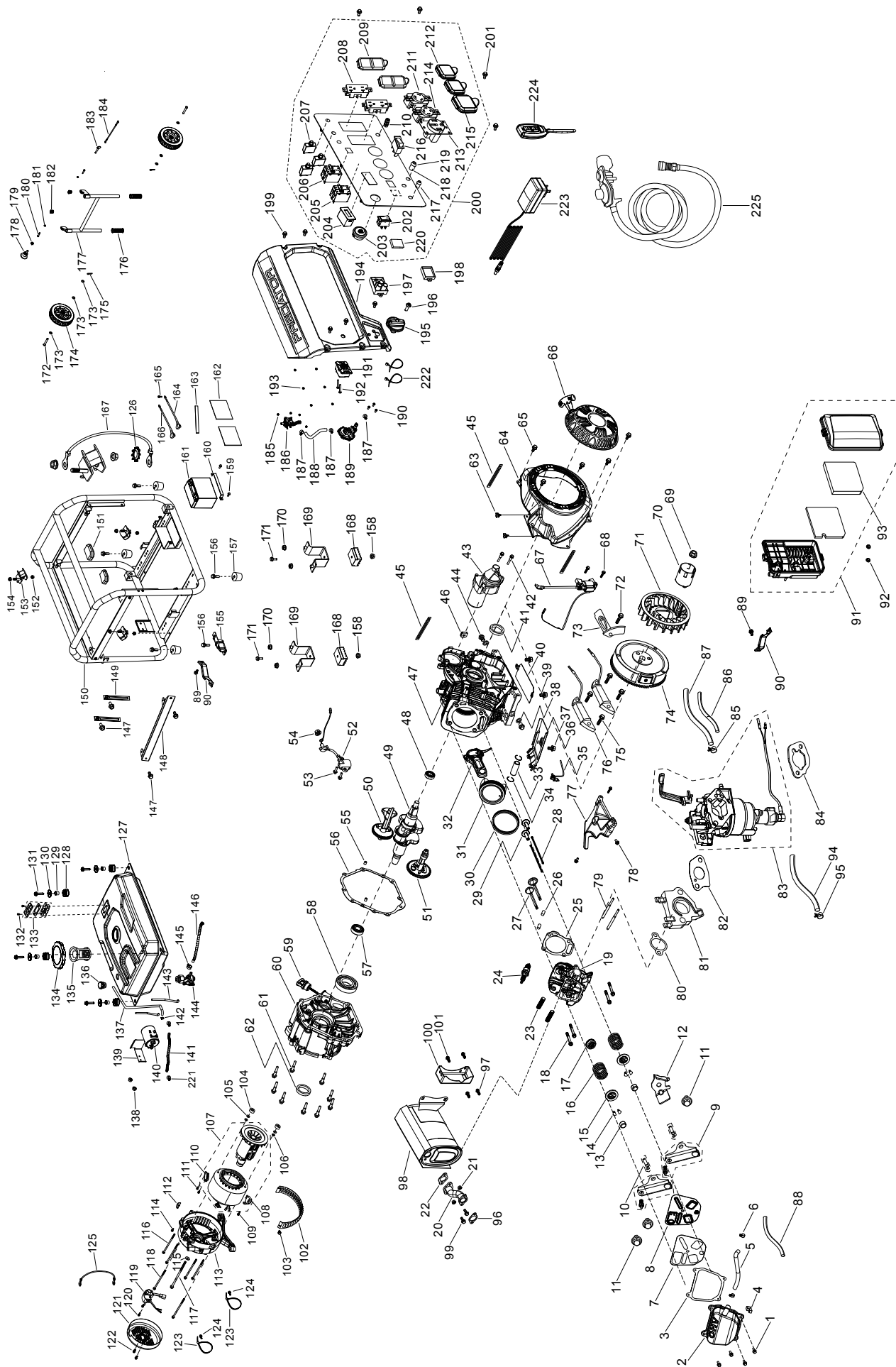

SAFETY

SETUP

OPERATION

MAINTENANCE

Limited 90 Day Warranty (Retail)

SAFETY

Harbor Freight Tools Co. makes every effort to assure that its products meet high quality and durability standards, and warrants to the original purchaser that this product is free from defects in materials and workmanship for the period of 90 days from the date of purchase. This warranty does not apply to damage due directly or indirectly, to misuse, abuse, negligence or accidents, repairs or alterations outside our facilities, criminal activity, improper installation, normal wear and tear, or to lack of maintenance. We shall in no event be liable for death, injuries to persons or property, or for incidental, contingent, special or consequential damages arising from the use of our product. Some states do not allow the exclusion or limitation of incidental or consequential damages, so the above limitation of exclusion may not apply to you. THIS WARRANTY IS EXPRESSLY IN LIEU OF ALL OTHER WARRANTIES, EXPRESS OR IMPLIED, INCLUDING THE WARRANTIES OF MERCHANTABILITY AND FITNESS, EXCEPT FOR THE EMISSIONS CONTROL SYSTEM WARRANTY BELOW.

SETUP

To take advantage of this warranty, the product or part must be returned to us with transportation charges prepaid. Proof of purchase date and an explanation of the complaint must accompany the merchandise. If our inspection verifies the defect, we will either repair or replace the product at our election or we may elect to refund the purchase price if we cannot readily and quickly provide you with a replacement. We will return repaired products at our expense, but if we determine there is no defect, or that the defect resulted from causes not within the scope of our warranty, then you must bear the cost of returning the product.

This warranty gives you specific legal rights and you may also have other rights which vary from state to state.

OPERATION

MAINTENANCE

Emissions Control System Warranty

Harbor Freight Tools (HFT) is pleased to explain the emissions control system warranty on your Small Off-Road Engine produced after January 1, 2024 (engine), in addition to the Retail Warranty above. HFT warrants that the emissions control system on your engine is designed, built, and equipped so that it conforms to the United States Environmental Protection Agency's (EPA) emissions requirements in effect at the time of manufacture. HFT also warrants that the emissions control system on your engine will be free from defects in material and workmanship for two (2) years, provided there has been no improper maintenance, misuse, or abuse of your engine.

Your emissions control system may include parts such as the carburetor or fuel-injection system, and the ignition system. Also included may be hoses, belts, connectors and other emissions-related assemblies.

WHAT WE WILL DO

Where a warrantable condition exists, HFT will repair or replace, at our option, any emissions-related part on your engine if it becomes defective, malfunctions, or otherwise fails to conform with this warranty under normal use and service during the two (2) year term of this warranty at no cost to you, including diagnosis, parts and labor. This warranty applies to the original purchaser and any subsequent owner within the two year warranty period.

WHAT IS COVERED?

The following parts are examples of components of the emissions control system and are covered by this two (2) year warranty. For a full list of emissions control components covered by this warranty, please see 40 CFR §1068, Appendix I.

1. Fuel Metering System
 - a. Carburetor and its internal parts.
 - b. Fuel pump (if so equipped).
 - c. Cold start enrichment system.
2. Air Induction System
 - a. Intake pipe/manifold.
 - b. Air cleaner.
3. Ignition System
 - a. Spark plug.
 - b. Magneto ignition system.
4. Catalyst System (if so equipped)
 - a. Exhaust pipe stud.
 - b. Muffler.
 - c. Catalytic converter (if so equipped).
5. Miscellaneous Items Used in Above Systems
 - a. Vacuum, temperature and time sensitive valves and switches.
 - b. Hoses, belts, connectors, and assemblies.

This warranty does not cover normal maintenance services or replacement of maintenance items such as filters, oils, or spark plugs.

WHAT YOU MUST DO TO OBTAIN WARRANTY SERVICE

As the engine owner, you are responsible for the performance of the required maintenance listed in your Owner's Manual. HFT may deny you warranty coverage if your engine or a part has failed due to abuse (including failure to follow the fuel use instructions contained in this manual), neglect, improper maintenance, or unapproved modifications.

In order to obtain warranty repair or replacement, you may either (a) contact HFT product support at 1-800-444-3353 or productsupport@harborfreight.com; or (b) bring the engine/equipment to your nearest Harbor Freight Tools retail store. When going to the retail store or contacting product support, you must indicate the specific emissions control part or defect that you are claiming and the date this was originally purchased. The nearest Harbor Freight Tools retail store can be found on the internet at <https://www.harborfreight.com>.

SAFETY

SETUP

OPERATION

MAINTENANCE

PREDATOR®

26677 Agoura Road • Calabasas, CA 91302 • 1-800-444-3353